



INSTRUCTION MANUAL

Installation | Maintenance | Use | Safety

Blender 2,8 L



Model

BLA.2,8

Image merely illustrates.

CONGRATULATIONS,

You have just purchased a IMG-BRASIL equipment, product of the highest quality, safety and efficiency.

Founded in 1989, IMG-BRASIL is a respected company as one of the best and most complete companies in the field of gastronomy equipment manufacturing.

Constant innovation and improvement of its products, using top-of-line raw materials, ensure superior products consumed in Brazil and in more than 25 countries worldwide.

THE RELIABILITY AND CERTAINTY OF A GOOD PRODUCT ARE IN THE NAME



IMPORTANT:

**PRODUCT FOR PROFESSIONAL USE. DO NOT USE BEFORE READING THE MANUAL CAREFULLY.
IN CASE OF QUESTIONS, PLEASE CONTACT US::**

IMG-BRASIL Gastronomy Machinery Industry Ltda.

CNPJ 11.193.347/0001-14 - CREA 131726-3

Road. Antônio Heil – KM 23 N° 5825 – Neighborhood: Limoeiro – ZIP CODE 88352-502
Brusque – SC – Brasil

Phone/fax. +55 47 3251-5555 - Website: www.metvisa.com.br

INDEX

1. Safety Information	4
1.1 General Warnings.....	4
1.2 Mechanical Safety	5
1.3 Electrical Safety.....	6
2. Technical Characteristics	6
2.1 Main Components.....	6
2.2 Technical Data.....	7
2.3 Supply and Disposal of Equipment Packaging.....	8
3. Installation	8
3.1 Equipment Layout.....	8
3.2 Electrical Connection	9
3.3 Safety Procedures and User Instruction.....	10
4. Equipment Use	10
4.1 Utility.....	10
4.2 Commands	11
4.3 Operating Procedures.....	11
5. Cleaning and Maintenance	13
5.1 Cleaning Procedures and Products Used	13
5.2 Breakdown Maintenance and Procedures.....	15
5.3 Prolonged Interruption in Use of the Equipment.....	16
6. Analysis and Troubleshooting	16
6.1 Problems, possible causes and solutions	16
7. Useful Life of the Equipment and its Components	17
8. Applicable Standards	17
9. ANNEXES	18
Electrical Schematic Voltage 110V, 127V or 220 V.....	18



ATTENTION!

The characteristics, pictures and figures presented in this manual should be considered for information. IMG BRASIL reserves the right to make such modifications as may be deemed necessary without prior notice.

1. Safety Information

1.1 General Warnings

- Cautions / precautions must be observed when installing, using, maintaining and discontinuing use of this equipment;
- Before carrying out any operation (assembly, use, maintenance and reuse after prolonged use of the equipment), read the manual carefully;
- The equipment must be used by trained personnel familiar with the use and safety regulations described in this manual;
- This equipment is not intended for use by persons (including children) with reduced physical, sensory or mental capacities, or people with lack of experience and knowledge, unless they have received instructions regarding the use of the equipment or are under the supervision of a person responsible for their safety.
- It is recommended that children be supervised to ensure that they are not playing with the equipment;
- In case of rotation of the personnel that will work with the equipment, the new operator must be educated about the standards and the operation of the same one;
- The operator must use the **Adequate PPE** (Personal Protective Equipment). As for example: use hair caps, preventing them from locking in the equipment's moving parts;
- The operator must always be aware of situations that may cause the risk of accidents and avoid them. For example: avoid working with loose uniform sleeves, where they could catch on moving parts, causing accidents;
- After reading and clarifying all doubts, this manual should be carefully stored in an easily accessible location, known to all persons who will operate the equipment and make it available to those who will carry out maintenance for any inquiries. Whenever any questions arise, be sure to check the manual. Do not operate the equipment in any way with doubts;
- Before starting cleaning and any type of maintenance, it is essential to disconnect the equipment from the electrical supply;
- Periodically check the condition of power cords and electrical parts;
- In the installation, it is essential to make this manual available to the professionals who will do the same;
- Never place your hands, fingers or objects inside the cup with the equipment turned on, as this could cause an accident;
- Never turn on the equipment with the cup uncovered, nor should you remove the cup while the equipment is turned on;
- Do not leave the equipment turned on without supervision and working for more than 3 minutes uninterruptedly;
- These equipments are intended for domestic use and similar applications such as: store kitchens, offices and other similar workplaces; farmhouses; by customers in hotels, motels and other similar locations; bedroom environments and small meals.



ATTENTION!

Do not perform repairs on your own. Go to a service center authorized by the manufacturer. Use only original parts in your equipment.

1.2 Mechanical Safety

Only insert specific products for what the equipment is intended for and never place your hands, fingers or objects inside the cup with the equipment turned on, as this could cause an accident.

Before turning on the equipment, make sure the cup is well fitted into the coupling and cup holder. Also check that the lid is fitted to the cup.



When the equipment is turned off and you are handling the cup containing the blades, be extremely careful. The blades are very sharp and are exposed and can easily cause accidents (cuts, for example) if the cup is not handled carefully.

The equipment described in this manual complies with regulations against mechanical risks. The requirements of the standard were observed: INMETRO (see item 8 Applicable Standards).

Mechanical safety is achieved with:

- **Mechanical design** that makes it impossible to access electrical parts by hand;
- **Structure**, which protects the entire motor, avoiding contact with water, dust and other materials;
- **Lid**, which prevents splashes from spilling out of the cup and protects the operator when processing food;
- **Overlid**, allows the operator to view the food or add ingredients during processing without the need to remove the lid;
- **Base** of the equipment with non-slip feet, and with a small ventilation opening, preventing hand access to electrical parts;

To view the components, see item 2.1 (Main Components) of this manual.



ATTENTION!

Always that some item referred to safety be removed from the equipment (for example, for cleaning or maintenance), replace it in place and confirm that it is performing its function correctly.

1.3 Electrical Safety

- Periodically check the condition of power cords and electrical parts;
- If the power cord is damaged, it must be replaced with a new one. The exchange must be carried out by the manufacturer, an authorized agent or a qualified person in order to avoid risks;
- Do not use water jets, as it may cause electric shock. To clean your equipment, follow the instructions in item 5 of this manual;
- Do not work with the equipment in damp places, or with wet clothes and shoes. Put on proper footwear, this will avoid electric shocks and even death;
- Place the equipment on a firm, dry and well-leveled surface;
- Do not use extension cords or adapters with various other equipments connected to them. This could cause fire or overload;
- Never carry out any maintenance, adjustment or disassembly operation on the equipment with it turned on. For such procedures, make sure that it is turned off, removing the plug from the electrical network.

The components used for safety against electrical hazards have been selected in accordance with applicable standards. Given the perfect insulation of all electrical parts and the excellent resistance of all the materials used, this equipment is capable of carrying out the tasks it is intended to do.



ATTENTION!

Always that some item referred to safety be removed from the equipment (for example, for cleaning or maintenance), replace it in place and confirm that it is performing its function correctly.

2. Technical Characteristics

2.1 Main Components

For the equipment described in this manual, safety in use, cleaning, maintenance and maximum hygiene are guaranteed by the design and special design of all parts, as well as the use of stainless steel and other materials suitable for contact with the foods.

The equipment was designed with the following characteristics:

- **Lid** made from non-toxic plastic. Material resistant to citric acid (found in lemon and orange juice), it is easy to maintain, hygienic and resistant to corrosion;
- **Cup** made from high-resistance polycarbonate.
- **Structure** and **Cup Support** made from non-toxic ABS plastic, highly resistant and hygienic.
- The **Blades** are made of stainless steel, which is resistant to wear. It resists aggressive agents well, such as fruit and vegetable juices, some mild acids and alkalis, contaminant-free water vapor, etc.

See below the main components of the equipment:



Description:

- 1. Overlid;
- 2. Lid;
- 3. Cup;
- 4. Structure;
- 5. Speed Controller;
- 6. Pulse/On/Off switch;
- 7. Cup Holder.

Note: For exploded drawing with spare parts list, see annexes.

2.2 Technical Data

Model	Nominal Measures LxHxW (mm)	Net Weight (kg)	Voltage (V)	Nominal Power (W)	Nominal Capacity (L)
BLA2,8127CC5	219 x 508 x 240	4,3	127	1200	2,8
BLA2,8220CC5			220		

Noise level (equipment loaded): 75 dB.



ATTENTION!

Characteristics like: model, serial number and voltage of the equipment are provided on the label (figure below). Before installation, check that the power supply voltage of the equipment corresponds to that of the mains.

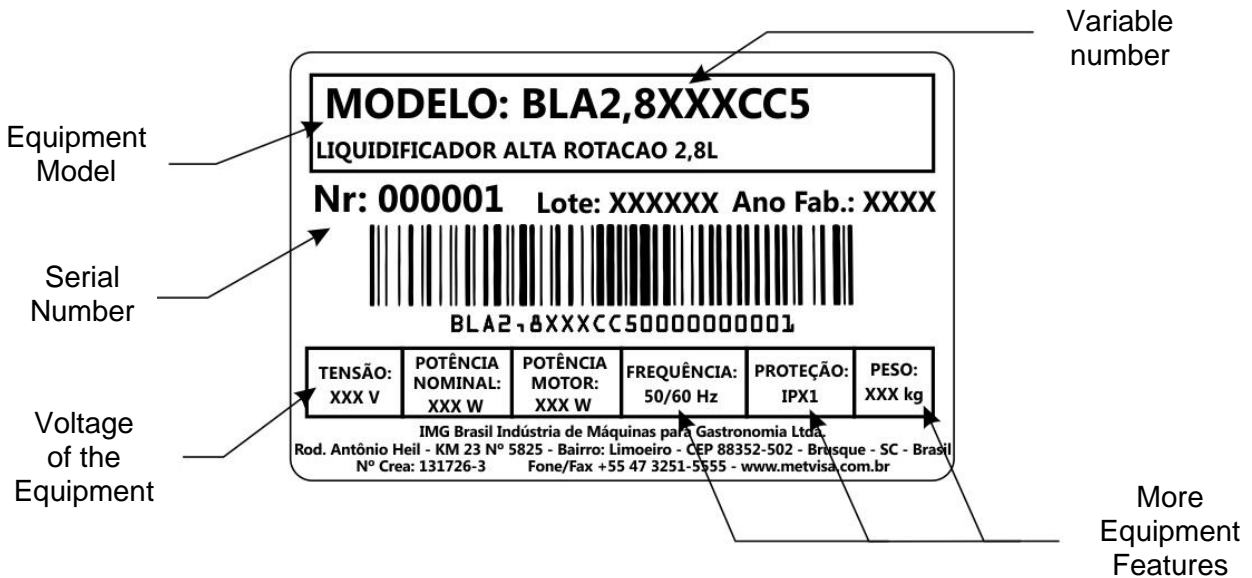

2.3 Supply and Disposal of Equipment Packaging

The equipment is packed with wood or cardboard to ensure its perfect integrity during transport and is accompanied by the following documents:

- Instruction Manual for Installation. Use, Maintenance and Safety;

IMPORTANT

The packaging components (cardboard, wood, foam, strips, etc.) are products that can be assimilated to municipal solid waste and can be disposed of without difficulty. If the equipment is installed in countries with different standards, dispose of the packaging in accordance with current regulations. Dispose of the product correctly to help protect the environment. For more information on recycling, contact your local authorities, waste disposal service or the shop where you purchased the product.

3. Installation

3.1 Equipment Layout

Connection to the electrical network and provision for operation must be carried out by a qualified professional. Check that the equipment's voltage matches that of the mains.

During installation, it is essential to make this manual available to the professionals who will carry out the installation.

To guarantee correct operation and safety, the equipment must be positioned in a ventilated environment and on a sufficiently large, well-leveled, dry and stable support surface, away from heat sources and water taps, and at a medium height. 80 cm. Install your equipment leaving a distance of at least 20 cm around it, so that there is enough space for inspection, maintenance, cleaning and use.



ATTENTION!

The installation and the place where the equipment will be placed must comply with the rules of risk prevention and safety at work (Regulatory Norm NR-12 for Brazil or according to the regulatory standard in force in your country).

The manufacturer is not responsible for possible direct or indirect damages caused by non-compliance with said standards and other instructions presented in this manual.

3.2 Electrical Connection

The equipment is supplied with a power cord to be connected to an electrical network. If the power cord is damaged, it must be replaced with a new cord. The exchange must be carried out by the manufacturer, authorized agent or qualified person in order to avoid risks.

The plug type of the power cord varies by country. The equipment must be installed by a qualified technician for this function and in compliance with the regulations in force in the country, especially with regard to the earth connection (if applicable).

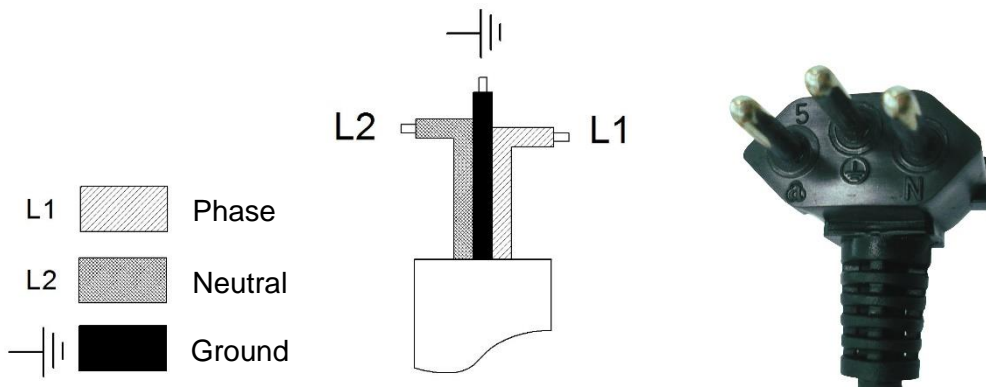

The equipments described in this manual are single voltage, that is, 110 V, 127 V or 220 V. If it is necessary to change the voltage on your equipment, contact the manufacturer or authorized dealer



ATTENTION!

Before turning on your equipment, always check that the mains supply voltage is the same as the equipment voltage.

The supply voltage of this equipment is 110 V and 127 V (60 Hz) or 220 V (50 or 60 Hz) single-phase, as can be verified on the voltage label affixed to the power cable or as indicated on the nameplate data label, which is located on the back side of the equipment (see the figure on this label in item 2.2 of this manual).

Make sure that the voltage of the electrical network where the equipment will be installed is compatible with the voltage indicated on these labels.

For more details on the rest of the electrical part of the equipment, refer to the electrical diagram in the annexes of the manual.

IMPORTANT

The manufacturer is not responsible for possible direct or indirect damage caused by non-compliance with the rules and instructions presented in this manual.

3.3 Safety Procedures and User Instruction

The professional who sells the equipment must instruct the user on the correct functioning of the equipment and must hand over this instruction manual.

The user must be informed of the necessary safety measures and must respect them, as well as all measures described in this manual.

Your equipment has mechanical protections (see item 1.2 Mechanical Safety). Removing or tampering with these safety components can cause serious risks to the operator's upper limbs.

4. Equipment Use

4.1 Utility

This equipment is exclusively intended for crushing light food products with the addition of liquid and dissolving frozen fruit pulps, and must be exclusively for domestic use and not intended for any other purpose.

IMPORTANT

It is not recommended to process dense foods.

For dense foods such as: mayo, cake dough or savory doughs, the use of the LQ line (BIMG/METVISA Low Rotation Blender) is recommended. For Milk Shake use the BMK (BIMG/METVISA Milk Shake Mixer).

4.2 Commands

The equipment consists of an on/off switch, positioned on the front of the structure (image below).



See switch description:

1. **Pulse/Off/On switch** – used to turn on, off or pulse the equipment.
2. **Speed Controller** – used to gradually regulate speed.

4.3 Operating Procedures

Before operating your equipment, thoroughly clean the items that will come into contact with food (cup, lid and over-cap). Carry out cleaning with the equipment disconnected from the mains. Follow the cleaning instructions in item 5 of this manual.

Make sure the cup is securely fitted into the coupling and cup holder. Also check that the equipment's power supply voltage matches that of the mains. Do not lift the cup when the equipment is on.



This is a high-speed blender. Always keep the equipment out of the reach of children.

The equipment can mix breakable solids, dry solids, semi-liquid and liquid food materials. It is recommended that the size of the food, when inserted into the cup, is around 3 to 5 cm.

After checking these items, follow the equipment's operating processes below:



ATTENTION!

To avoid damaging the equipment, never turn it on with the cup empty. Before turning it on, add liquid in a minimum amount twice the height of the blade.

Do not insert foods with a texture and density similar to Cupuaçu, as this may compromise the performance and functioning of the equipment.

- Connect the power cord to the electrical network;
- Add the liquid according to your recipe, but always respecting the “MAX” level. indicated on the cup;



- Before turning on your equipment, always fit the lid with the overcap onto the cup;
- To start processing, turn the equipment on to the position  (on);
- To add ingredients during processing, remove the overcap by turning it counterclockwise and pulling it vertically upwards. Use the opening in the lid without having to remove it. Once you have the pre-cut pieces of food (approximately 2 cm), place them in the cup;
- You can also use the pusher to stir the food inside the cup and obtain a more homogeneous mixture. If necessary, hold the cup by the handle.
- It is recommended that the equipment does not run for **more than 2 minutes uninterruptedly**. Periodic verification must be carried out to assess the quality of the final product.

- After the process is complete, turn off the equipment by pressing the switch in the central position and unplug the equipment.

IMPORTANT

When processing a liquid that is hot, remove the overcap to allow steam to escape. For your safety, the temperature of processed products cannot exceed 40°C.

If food sticks to the wall of the cup, turn off the equipment and disconnect the plug from the socket. Use a spatula to remove food from the wall of the cup.



ATTENTION!

Never turn on the equipment with the cup uncovered, nor should you remove the cup while the equipment is running.

Do not place your fingers, hands or objects (such as spoons and knives) inside the cup, as this could cause accidents.

To add ingredients or view the food being processed, remove only the overcover.



ATTENTION!

This equipment is intended for domestic use and must not be used for any other purpose.

Do not leave the equipment running for more than 3 minutes uninterruptedly. If processing has not finished after this time, leave it to rest for 10 minutes before putting it back into operation.

To avoid damaging the equipment, never turn it on with the cup empty.

It is not recommended to process dense foods. To crush solid foods, add liquid, otherwise overheating may occur, damaging the cup sealing system, wear and/or breakage of the blades and other components of the equipment.

If you notice that the equipment is unable to process the food or that it is stopping processing, reduce the quantity or size of the food in the pre-cut process, before inserting it into the cup.

Failure to follow these guidelines will be considered an unsafe act and abusive use of the equipment.

If there is any irregularity, contact the nearest authorized technical assistance department.

5. Cleaning and Maintenance

5.1 Cleaning Procedures and Products Used

Your equipment was built with first-line materials, so use it properly and you will obtain great satisfaction. Always keep your equipment clean and well-cared for, which will make it much more durable.

Daily cleaning of the equipment must be carried out for good operation and durability. Preventing the accumulation of bacteria which can cause contamination in food.



ATTENTION!

Before carrying out maintenance or cleaning, ensure that the on/off switch is in the “” (off) and the plug is disconnected from the mains.



ATTENTION!

Do not use water jet or steam to clean the equipment.

IMPORTANT

This equipment **is not intended** to be immersed in water for cleaning. Follow the instructions below to learn the parts that can be immersed and what special care is taken with the other parts.

To remove heavy dirt from the cup, follow the instructions below:

1. Fit the cup into the coupling and cup holder;
2. Add warm water (500ml less than the maximum capacity of the cup or at least twice the height of the blade) and a few drops of neutral detergent into the cup;
3. Place the lid and turn on the equipment for a few seconds;
4. When turning off the equipment, remove the cup from the support and rinse under running water.

The cup, lid and overcap must be washed with water and neutral soap. Clean the corners well, eliminating food residue.

The rest of the equipment should only be cleaned with a damp cloth as many times as possible, to prevent food residues from drying out and sticking to the parts. Dry all parts that have been cleaned with a dry, soft cloth.

Never use abrasive products or sponges and substances containing acids or chlorine to clean metal parts, as they can scratch or damage the surface of the parts, causing corrosion spots. Do not pour water on the equipment for cleaning, otherwise turning it on could cause an electric shock or even burn the equipment.



ATTENTION!

Before first use, cleaning must be carried out as per the instructions above. Some smoke and smell may occur due to the burning of the non-toxic lubricant on the shaft.

Take care when cleaning the cup, as the blades are extremely sharp. Handle with care, otherwise it could cause accidents. The same attention applies to any other sharp component of the equipment.

IMPORTANT

The manufacturer is not responsible for possible direct or indirect damage caused by non-compliance with the rules and instructions presented in this manual.



ATTENTION!

It is extremely important that the products used for cleaning ensure maximum hygiene and that they are non-toxic.

5.2 Breakdown Maintenance and Procedures

The operator must be instructed to carry out routine inspections, making small adjustments, cleaning and observing signs of breakdowns that may occur. Examples include: checking for strange noises indicating gas leaks; burners that do not light; the non-execution by the equipment to the service to which it is proposed; among others. Actions like these are indispensable to guarantee a longer equipment life.



ATTENTION!

When carrying out maintenance (even small adjustments), always disconnect the equipment from the mains.



ATTENTION!

The blades can be resharpened when they lose their edge. To do this, contact the nearest technical assistance.

It is recommended that each 6 months be made preventive maintenance, checking and adjusting the loose, cleaning the internal parts, and others. Detecting broke parts or without the correct functionality the worker needs to exchange the parts, always using original parts only.

By carrying out preventive maintenance, the inconvenience of having the equipment stopped when it is most needed is eliminated, the cost of maintenance is reduced and the risk of accidents is reduced.

When carrying out maintenance on the bearing, make sure that the assembly is correct, as incorrect assembly may cause wear or breakage. Check the guidance below for correct assembly of the bearing.

BOTTOM VIEW OF THE CUP BEARING ASSEMBLY

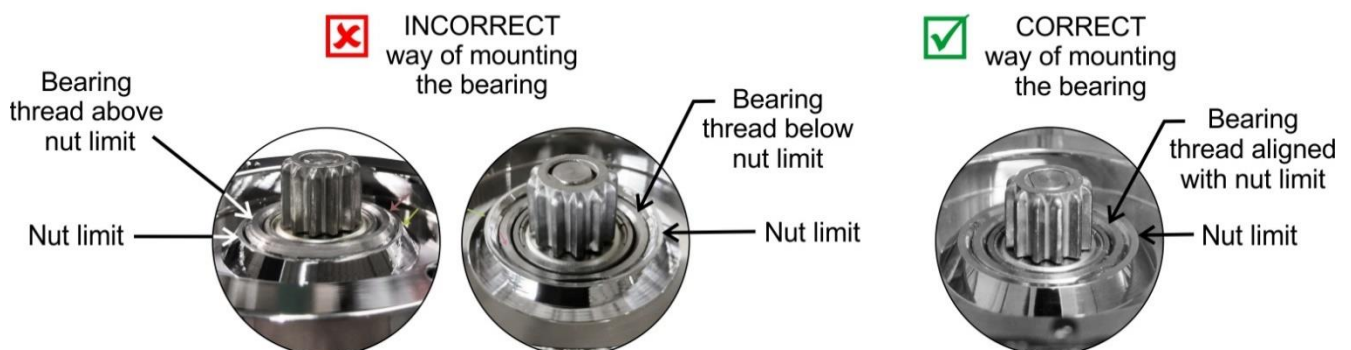



ATTENTION!

Preventive maintenance requires a trained professional.

Make sure the equipment is disconnected from the mains.

Whenever any item related to the safety of the equipment is removed (such as when carrying out maintenance), replace it in its proper place and confirm that it is performing its function correctly.

Detecting broke parts or without the correct functionality, please contact the nearest authorized service center: www.metvisa.com.br

5.3 Prolonged Interruption in Use of the Equipment

When you have to leave the equipment stopped for an extended period of time, perform a thorough cleaning, including the accessories. It is advisable to protect all parts of the equipment with white petroleum jelly or with suitable products that are commercially available. You must also protect the equipment from dust by covering it with a nylon or other material.

6. Analysis and Troubleshooting

6.1 Problems, possible causes and solutions

IMG quality products are designed with materials and components that guarantee a longer service life for your equipment. However, due to natural wear, improper use or lack of maintenance, the equipment may have irregularities in its operation.

In the following table, you can see possible causes and solutions:

PROBLEMS	POSIBLE CAUSES	SOLUTIONS
Equipment does not turn on.	- Lack of electricity	- Check if there is power in the electrical network; - Check connection of the power cord to the electrical network; - Check that the switches are in the correct position.
	- Poor contact in internal electrical connections.	- Contact or send the equipment to Authorized Technical Assistance.
	- Equipment voltage different from the mains voltage.	
The blades stop rotating during operation.	- Problems with the motor.	
	- Lack of electricity	- Check whether there is poor contact in the connection of the power cord to the electrical network.
	- Cup poorly fitted to the coupling and/or cup support.	- Check the images of the coupling and support in the Mechanical Safety item.
	- Food locked in the blades.	- Turn off the equipment and disconnect the plug from the socket. Use a spatula to remove food from the blade.

The equipment turns on, but rotates at low speed when it comes into contact with the food.	- Problems with the motor.	- Contact or send the equipment to Authorized Technical Assistance.
	- Grinding solid foods without adding any liquid.	- Reduce the quantity or size of the food in pre-cutting, before inserting it into the cup and adding liquid.
Burning and/or smoke smell.	- Equipment voltage different from the mains voltage.	- Contact or send the equipment to Authorized Technical Assistance.
	- Problems with the motor.	
	- Poor contact in internal or external electrical connections.	- Never turn on the equipment with the cup empty. Before turning it on, add liquid in a minimum amount twice the height of the blade.
Strange noises.	- Equipment switched on with the cup empty or with little liquid.	- Check the images of the coupling and support in the Mechanical Safety item.
	- Cup poorly fitted to the coupling and/or cup support.	- Contact or send the equipment to Authorized Technical Assistance.
Damaged electrical power cord.	- Parts poorly fixed	Changing the electrical power cord must be carried out by the manufacturer, authorized agent or qualified person, in order to avoid risks.
	- Transport damage; - Improper use and/or disposal of the equipment.	
Difficulty grinding food.	- Blunt blades.	- Contact or send the equipment to Authorized Technical Assistance.
	- Grinding solid foods without adding any liquid.	- Reduce the quantity or size of the food in pre-cutting, before inserting it into the cup and adding liquid.

For more information and clarification, contact the Authorized Technical Assistance nearest you. See list of technical assistance on our website: www.metvisa.com.br

7. Useful Life of the Equipment and its Components

The equipment's useful life can vary from 3 to 5 years depending on the proper use, cleaning, maintenance and quality of its components.

Below is the useful life ratio of the main components:

- On/Off switch: 10000 uses;
- Electrical power cords and wires: 25 years
- Electrical terminals: 8 years.

8. Applicable Standards

The Brazilian standards applied for the development of the equipment and preparation of this manual are:

- Portaria 148 de 28 March 2022 from INMETRO;
- Portaria INMETRO n.º 6, de 05/01/2022.

9. ANNEXES

Electrical Schematic Voltage 110V, 127V or 220 V

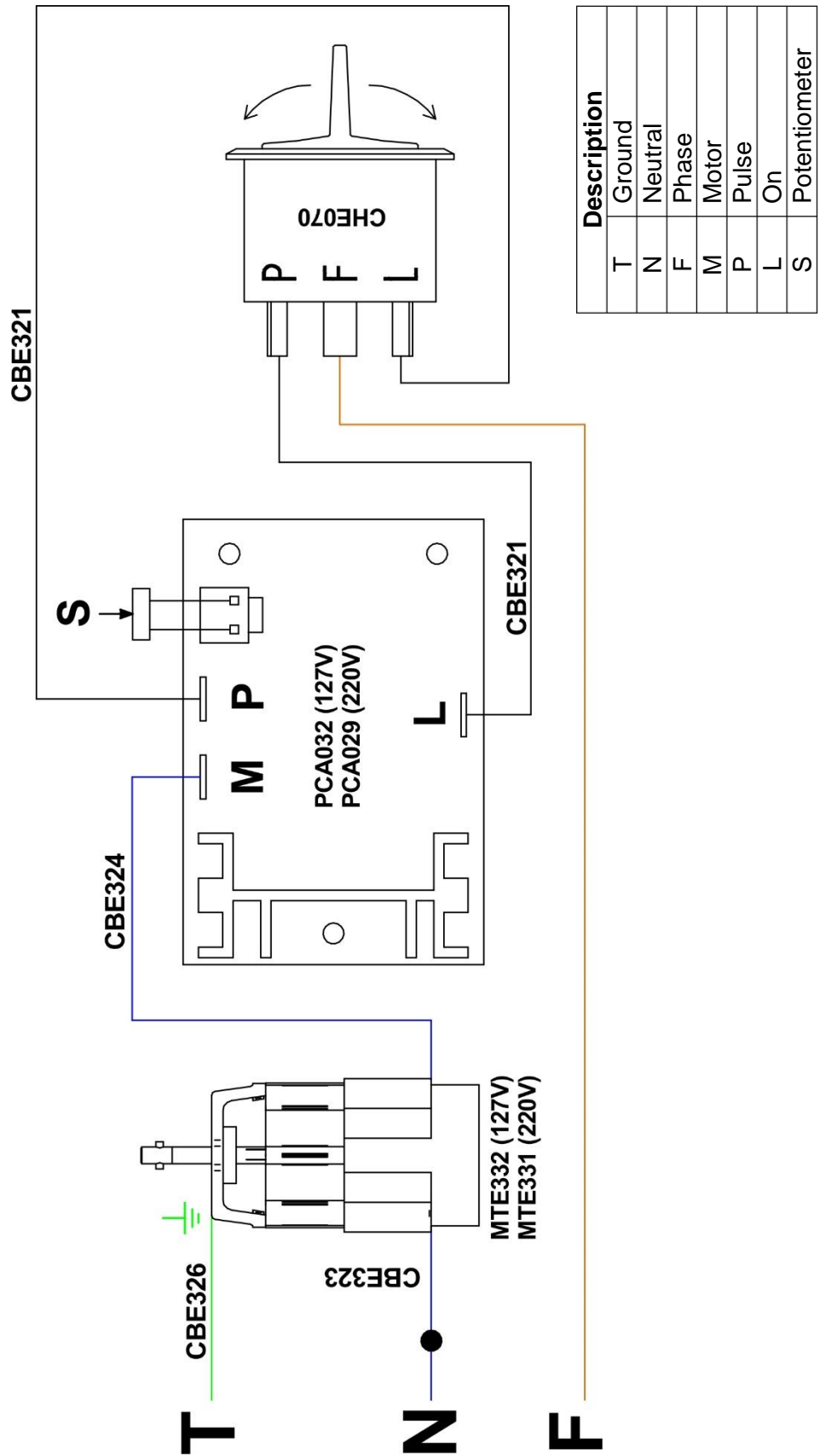

Description	
T	Ground
N	Neutral
F	Phase
M	Motor
P	Pulse
L	On
S	Potentiometer

Exploded View Drawing

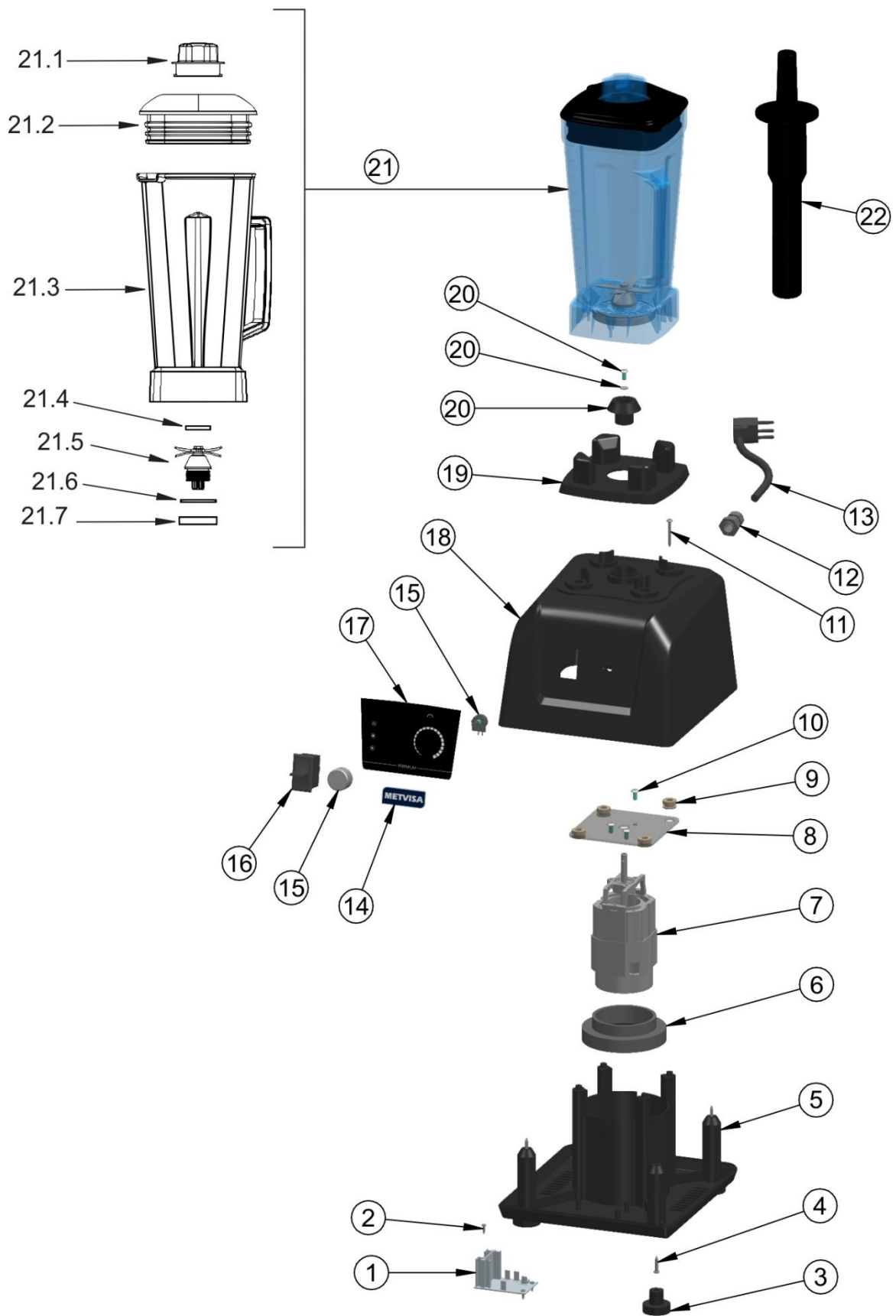

* Image merely illustrative.
Appearances can vary
according to the model.

Spare Parts List

Position	Code	Description	Qty.
1	PCA032	Electronic PC board 127V	1
	PCA029	Electronic PC board 220V	
2	PRA028	Stainless Steel Self-Tapping Screw	3
3	PEP034	Feet	4
4	PRA029	Stainless Screw	4
5	BAS158	Plastic Base Structure	1
6	BCH102	Motor Cushion	1
7	MTE332	Motor E. CC 127V	1
	MTE331	Motor E. CC 220V	
8	SBT623	Motor Support	1
9	BCH101	Motor Support Cushion	4
10	PRT071	Stainless Allen Screw	3
11	PRA030	Stainless Screw	4
12	TCE073	Cable Gland	1
13	CBE143	Electric Power Cord - 220V	1
	CBE144	Electric Power Cord - 127V	
14	ADE004	Metvisa Sticker	1
15	BOT051	Knob with Speed Control 127V	1
	BOT031	Knob with Speed Control 220V	
16	CHE170	Pulse/Off/On Switch	1
17	ADE220	Panel Sticker	1
18	GAB269	Structure	1
19	SBT427	Cup Holder 2,8L	1
20	ADA026	Coupling	1
21	CJT835	Complete Cup 2,8L	1
21.1	TAP165	Plastic Overlid	1
21.2	TAP167	Plastic Lid	1
21.3	COP114	Polycarbonate Cup 2,8 L	1
21.4	RET024	Silicone Retainer	1
21.5	CJT833	Complete Bearing	2
21.6	RET025	Silicone Retainer for Aluminum Ring	1
21.7	ANL033	Aluminum Ring - Nut	1
22	SQT024	Cup Pusher 2,8L	1

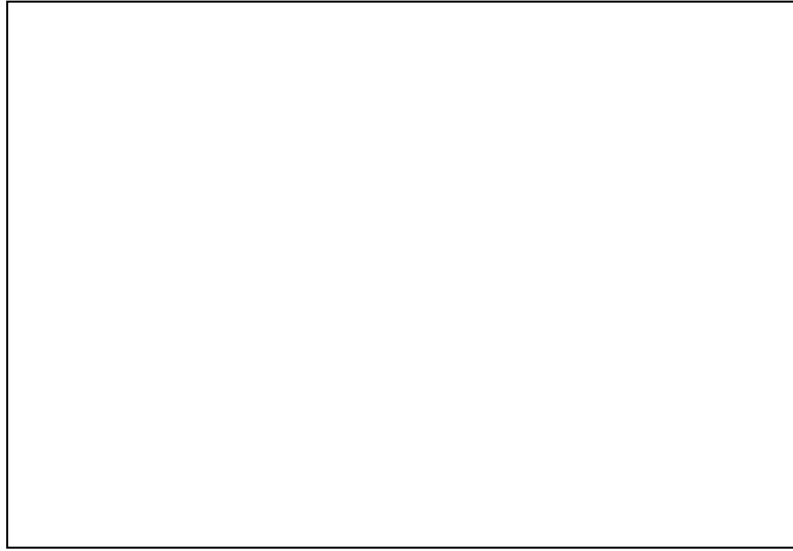

IMG BRASIL Gastronomy Machinery Industry Ltda.

CNPJ 11.193.347/0001-14 - CREA 131726-3
Road Antônio Heil - KM 23 Nº 5825 - Neighborhood: Limoeiro
ZIP CODE 88352-502 - Brusque - SC - Brazil
Phone/fax. +55 47 3251-5555 - Site: www.metvisa.com.br
Mail: sac@metvisa.com.br - export@metvisa.com.br



Know our complete
line of products.