

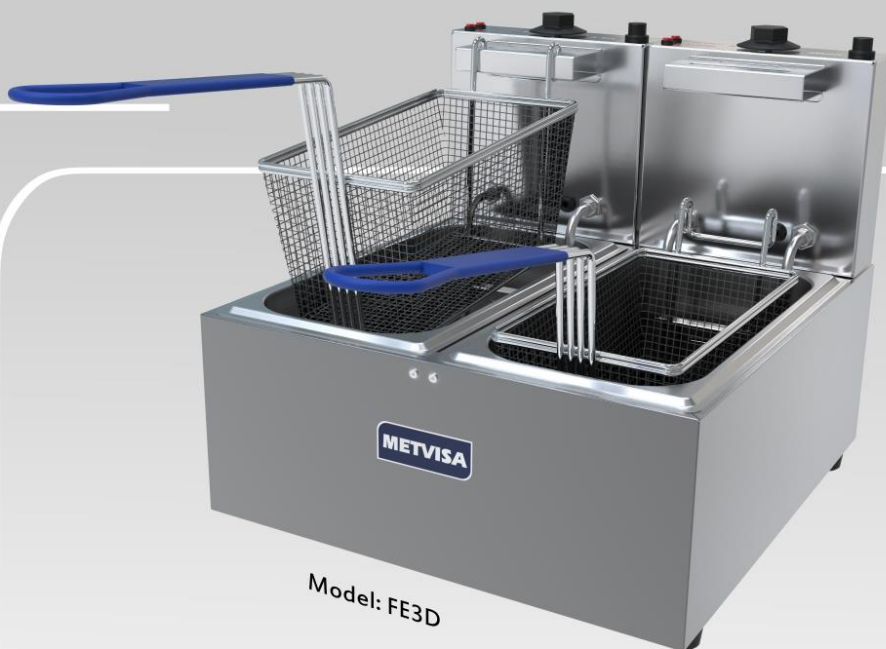

INSTRUCTION MANUAL

Installation | Maintenance | Use | Safety

Electric Fryer 3L



Models

- FE3S - Simple
- FE3D - Double
- FE3T - Triple

Image merely illustrates.

CONGRATULATIONS,

You have just purchased an IMG-BRASIL equipment, product of the highest quality, safety and efficiency.

Founded in 1989, IMG-BRASIL is a respected company as one of the best and most complete companies in the field of gastronomy equipment manufacturing.

Constant innovation and improvement of its products, using top-of-line raw materials, ensure superior products consumed in Brazil and in more than 25 countries worldwide.

THE RELIABILITY AND CERTAINTY OF A GOOD PRODUCT ARE IN THE NAME



IMPORTANT:

**PRODUCT FOR PROFESSIONAL USE. DO NOT USE BEFORE READING THE MANUAL CAREFULLY.
IN CASE OF QUESTIONS, PLEASE CONTACT US::**

IMG-BRASIL Gastronomy Machinery Industry Ltda.

CNPJ 11.193.347/0001-14 - CREA 131726-3

Road. Antônio Heil – KM 23 Nº 5825 – Neighborhood: Limoeiro – ZIP CODE 88352-502
Brusque – SC – Brasil

Phone/fax. +55 47 3251-5555 - Website: www.metvisa.com.br

INDEX

| | |
|---|-----------|
| 1. Safety Information | 4 |
| 1.1 General Warnings..... | 4 |
| 1.2 Mechanical Safety | 5 |
| 1.3 Electrical Safety..... | 6 |
| 2. Technical Characteristics | 7 |
| 2.1 Main Components..... | 7 |
| 2.2 Technical Data..... | 8 |
| 2.3 Supply and Disposal of Equipment Packaging..... | 9 |
| 3. Installation | 9 |
| 3.1 Equipment Layout..... | 9 |
| 3.2 Electrical Connection..... | 10 |
| 3.3 Safety Procedures and User Instruction..... | 12 |
| 4. Equipment Use | 12 |
| 4.1 Utility..... | 12 |
| 4.2 Commands..... | 12 |
| 4.3 Operating Procedures..... | 13 |
| 5. Cleaning and Maintenance | 17 |
| 5.1 Cleaning Procedures and Products Used..... | 17 |
| 5.2 Breakdown Maintenance and Procedures..... | 18 |
| 5.3 Prolonged Interruption in Use of the Equipment..... | 18 |
| 6. Analysis and Troubleshooting | 19 |
| 6.1 Problems, possible causes and solutions..... | 19 |
| 7. Useful Life of the Equipment and its Components | 20 |
| 8. Applicable Standards | 20 |
| 9. ANNEXES | 21 |
| Exploded View Drawing..... | 22 |



ATTENTION!

The characteristics, pictures and figures presented in this manual should be considered for information. IMG BRASIL reserves the right to make such modifications as may be deemed necessary without prior notice.

1. Safety Information

1.1 General Warnings

- Cautions / precautions must be observed when installing, using, maintaining and discontinuing use of this equipment;
- Before carrying out any operation (assembly, use, maintenance and reuse after prolonged use of the equipment), read the manual carefully;
- The equipment must be used by trained personnel familiar with the use and safety regulations described in this manual;
- This equipment is not intended for use by persons (including children) with reduced physical, sensory or mental capacities, or people with lack of experience and knowledge, unless they have received instructions regarding the use of the equipment or are under the supervision of a person responsible for their safety.
- It is recommended that children be supervised to ensure that they are not playing with the equipment;
- In case of rotation of the personnel that will work with the equipment, the new operator must be educated about the standards and the operation of the same one;
- The operator must use the **Adequate PPE** (Personal Protective Equipment). As for example: use kevlar hoses or non-flammable fabric to avoid burns with the oil; wear non-slip shoes; among others;
- The operator must always be aware of situations that can cause a risk of accidents and avoid them. For example: working on dirty floors where someone could slip and fall on the equipment;
- After reading and clarifying all doubts, this manual should be carefully stored in an easily accessible location, known to all persons who will operate the equipment and make it available to those who will carry out maintenance for any inquiries. Whenever any questions arise, be sure to check the manual. Do not operate the equipment in any way with doubts;
- In the installation, it is essential to make this manual available to the professionals who will do the same;
- Never pour water over hot oil, as this could cause major accidents. In the event of an accident, use non-flammable material to extinguish the fire. You can even place a metal tray or lid over the tank to muffle the fire;
- Before starting cleaning and any type of maintenance, it is essential to disconnect the equipment from the electrical supply and wait for the oil to cool completely;
- Periodically check the condition of the cables and electrical parts;
- Never put your hands, fingers or objects (such as spoons and knives) on the heating resistance or in the oil when the equipment is switched on or cooling down, as they will be hot and cause burns.
- These equipments are intended to be used for commercial applications, for example in restaurant kitchens, canteens, hospitals and in commercial enterprises such as bakeries, butchers, etc., but not for continuous mass production of food.



ATTENTION!

Do not perform repairs on your own. Refer servicing to qualified service personnel. Only use original parts in your equipment.

1.2 Mechanical Safety

- As the equipment is designed and produced for professional use, considering its purpose/utility, the manipulation of some components (for example: frying baskets) must be carried out with care;
- Before turning on the equipment, make sure that the temperature and safety thermostat bulbs are in perfect condition, that is, they cannot be dented or have any other fault. Faulty thermostats impair the correct functioning of the equipment and the temperature reading, which may cause accidents;
- Never pour water over the oil, as this could cause a serious accident;
- If you need to move some fried food, use a spatula;
- Your equipment has baskets for frying foods;
- Avoid spilling oil on the floor, as it will make the floor slippery and may cause accidents. In case of oil spills, clean the floor.

The equipment described in this manual complies with regulations against risks of a mechanical nature. The requirements of the standard were observed: INMETRO (see item 8 Applicable Standards).

Mechanical safety is ensured with:

1. **Structure**, that protects the entire frying tank (which is heated to high temperatures). This avoids burns to the operator;
2. **Frying basket**, which facilitates the handling of fried foods;
3. **Panel Coating**, which prevents operator access to electrical parts and protects all electrical components, avoiding contact with water, dust and other materials;
4. **Resistance protection** prevents contact between the frying basket and the heating resistance, avoiding the risk of burns and damage to the heating resistance.

To view the parts described above, refer to the image in item 2.1 (Main Components – page 7) of this manual.



ATTENTION!

Always that some item referred to safety be removed from the equipment (for example, for cleaning or maintenance), replace it in place and confirm that it is performing its function correctly.

1.3 Electrical Safety

- Periodically check the condition of cables and electrical parts;
- Never pour water over your equipment and do not use a steam cleaner. If the oil is hot, it may cause a serious accident and may even run into the electrical connectors and cause an electric shock;
- If the power cord is damaged, it must be replaced with a new one. The exchange must be carried out by the manufacturer or authorized agent or also by a qualified person, in order to avoid risks;
- Do not work with the equipment in damp places, or with wet clothes and shoes. Wear suitable footwear, this will prevent electric shocks and even death;
- Place the equipment on a firm and dry surface;
- Never carry out any maintenance, adjustment or disassembly operation on the equipment while it is switched on. For such procedures, make sure that it has been turned off, removing the plug from the electrical socket;
- Do not use extension cords or adapters with multiple other equipment connected to them. This may cause fire or overload;
- The equipment must be connected to an exclusive thermoelectric circuit breaker;
- To regulate the operating temperature of the equipment, there is a temperature thermostat button. This button must be used to adjust the temperature according to the needs of the product to be fried. We recommend adjusting the thermostat to a maximum of 180°C, avoiding overheating of the oil. When the temperature reaches the stipulated zone, the thermostat will turn off the resistance and automatically turn off the indicator light.
- The equipment also has a safety thermostat, which turns off the equipment in case the temperature thermostat fails. For more information on this thermostat, check item 4.2 (Commands) of this manual.

The components used for safety against electrical risks were selected in accordance with the Brazilian standard: NR-12 (see item 8 Applicable Standards). Due to the perfect insulation of all the electrical parts and the excellent resistance of all the materials used, this equipment is able to carry out the work for which it is proposed.



ATTENTION!

When you have to leave the equipment stopped for an extended period of time, disconnect it from the mains and turn off the circuit breaker.

Always that some item referred to safety be removed from the equipment (for example, for cleaning or maintenance), replace it in place and confirm that it is performing its function correctly.

2. Technical Characteristics

2.1 Main Components

For the equipment described in this manual, safety in use, cleaning, maintenance and maximum hygiene are guaranteed by the design and special design of all parts, as well as the use of stainless steel and other materials suitable for contact with the foods.

The equipment was designed with the following characteristics:

- Frying baskets in galvanized steel protecting the steel surface against corrosion. Non-toxic material and ideal for contact with food.
- Structure, panel, resistance protection and basket support made of stainless steel, which has a corrosion resistance superior to that of other steels. It is a material resistant to the attack of various corrosive agents;
- Frying tanks made of stainless steel 304, which resists the attack of various corrosive agents, such as most organic acids, organic substances in general, alkalis, oxy-salts, etc.

Attention: 304 stainless steel is attacked by sulfuric acid, and also does not resist hydrochloric acid, diluted sulfuric acid, chlorides and halides in general.

See below the main components of the equipment:

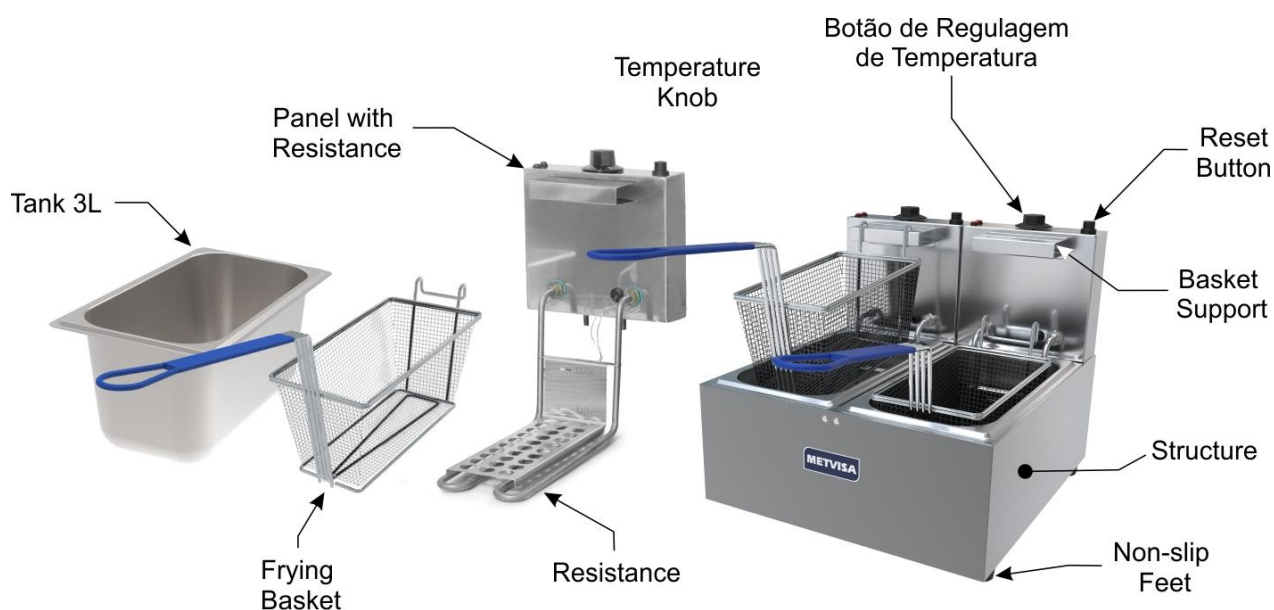

Note: For exploded view drawing with a list of spare parts, see the annexes.

2.2 Technical Data

| Model | Nominal Measures for Use WidthxHeightxDPTH (mm) | Net Weight (kg) | Voltage (V) | Rate of Each Resistance (A) | Quantity of Resistances | Energy Consumption (kW/h) | Capacity of each Tank (L) |
|----------|---|-----------------|-------------|-----------------------------|-------------------------|---------------------------|---------------------------|
| FE3S1275 | 200x360x580 | 7,3 | 127 | 19,8 | 01 | 2,5 | 3 |
| FE3S2205 | 200x360x580 | 7,3 | 220 | 12 | 01 | 2,5 | 3 |
| FE3S1104 | 200x360x580 | 7,3 | 110 | 19,8 | 01 | 2,5 | 3 |
| FE3S2201 | 200x360x580 | 7,3 | 220 | 12 | 01 | 2,5 | 3 |
| FE3S2202 | 200x360x580 | 7,3 | 220 | 12 | 01 | 2,5 | 3 |
| FE3S2204 | 200x360x580 | 7,3 | 220 | 12 | 01 | 2,5 | 3 |
| FE3D1275 | 380x360x580 | 8,2 | 127 | 19,8 | 02 | 5,0 | 3 |
| FE3D2205 | 380x360x580 | 8,2 | 220 | 12 | 02 | 5,0 | 3 |
| FE3D1104 | 380x360x580 | 8,2 | 110 | 19,8 | 02 | 5,0 | 3 |
| FE3D2201 | 380x360x580 | 8,2 | 220 | 12 | 02 | 5,0 | 3 |
| FE3D2202 | 380x360x580 | 8,2 | 220 | 12 | 02 | 5,0 | 3 |
| FE3D2204 | 380x360x580 | 8,2 | 220 | 12 | 02 | 5,0 | 3 |
| FE3T1275 | 570x360x580 | 11,9 | 127 | 19,8 | 03 | 7,5 | 3 |
| FE3T2205 | 570x360x580 | 11,9 | 220 | 12 | 03 | 7,5 | 3 |
| FE3T1104 | 570x360x580 | 11,9 | 110 | 19,8 | 03 | 7,5 | 3 |
| FE3T2201 | 570x360x580 | 11,9 | 220 | 12 | 03 | 7,5 | 3 |
| FE3T2202 | 570x360x580 | 11,9 | 220 | 12 | 03 | 7,5 | 3 |
| FE3T2204 | 570x360x580 | 11,9 | 220 | 12 | 03 | 7,5 | 3 |

Note: Mains power to the equipment requires a 25 A circuit breaker for 127 V or 110 V and 16 A for 220 V.

* Use dimensions considered with the frying basket assembled.



ATTENTION!

Characteristics like: model, serial number and voltage of the equipment are provided on the label (figure below). Before installation, check that the power supply voltage of the equipment corresponds to that of the mains.



2.3 Supply and Disposal of Equipment Packaging

The equipment is packed with wood or cardboard to ensure its perfect integrity during transport and is accompanied by the following documents:

- Instruction Manual for Installation. Use, Maintenance and Safety;

IMPORTANT

The packaging components (cardboard, wood, foam, strips, etc.) are products that can be assimilated to municipal solid waste and can be disposed of without difficulty. If the equipment is installed in countries with different standards, dispose of the packaging in accordance with current regulations. Dispose of the product correctly to help protect the environment. For more information on recycling, contact your local authorities, waste disposal service or the shop where you purchased the product.

3. Installation

3.1 Equipment Layout

Connection to the mains and layout must be carried out by a qualified professional. Check that the voltage of the equipment matches that of the mains.

During installation, it is essential to make this manual available to the professionals who will carry out the installation.

To ensure correct operation and safety, place the equipment in a well-ventilated area and on a support surface that is large enough, well leveled, dry and stable, away from heat sources and water taps, and at a medium height of 80 cm. Install your equipment leaving a distance of at least 20 cm around it, so that you have enough space for inspection, maintenance, cleaning and use.

It is recommended that the place where this equipment is installed/used be equipped with an appropriate fire extinguisher, in accordance with the standards and requirements of local legislation. The use of carbon dioxide extinguishers (also known as CO2 carbon dioxide extinguishers) is recommended. Do not use chemical powder or water extinguishers, as these will only increase the fire. Note: In case of fire, you can even place a tray or metal lid over the tank, to muffle the fire.

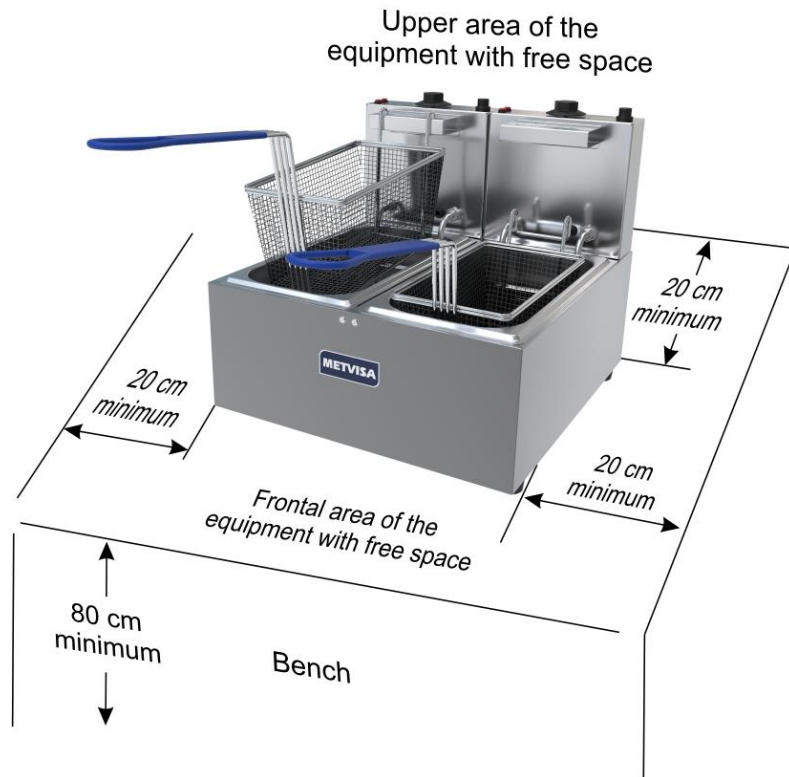

Another important recommendation is to install a hood or extractor above the equipment to collect the vapors, preventing them from spreading in the environment.



ATTENTION!

The installation and the place where the equipment will be placed must be in accordance with the Rules for the Prevention of Risks at Work and Safety at Work in Machines and Equipment.

The manufacturer does not take responsibility for possible direct or indirect damage caused by failure to comply with said standards and other instructions presented in this manual.

3.2 Electrical Connection

The equipment is supplied with a power cord to be connected to an electrical network. If the power cord is damaged, it must be replaced with a new cord. The exchange must be carried out by the manufacturer, authorized agent or qualified person in order to avoid risks.

The plug type of the power cord varies by country. The equipment must be installed by a qualified technician for this function and in compliance with the regulations in force in the country, especially with regard to the grounding connection (if applicable).

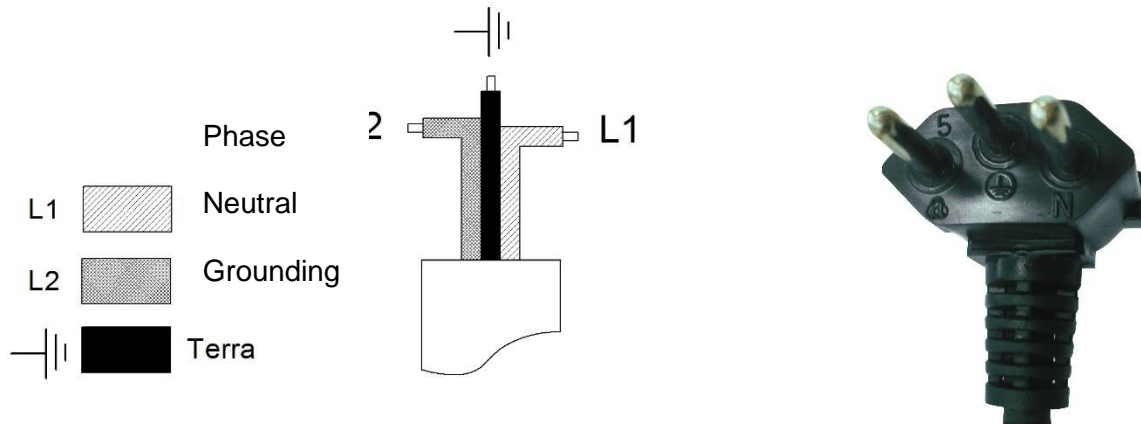

All equipment models described in this manual are single-phase and have a single voltage, that is, 110 V, 127 V or 220 V. If you need to change the voltage on your equipment, contact the manufacturer or authorized dealer.

The fryer also comes with an equipotential grounding terminal (terminal), located on the lower rear base of the structure.

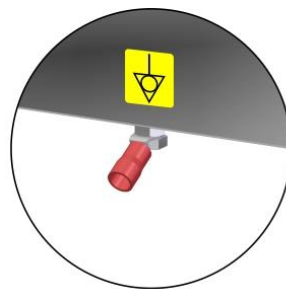

Equipotential grounding terminal



The terminal identified in the figure aside is an additional protection to the grounding that is provided for in the electrical network, it must be connected to a grounding terminals, regardless of the connection to the electrical network, and the other products that have accessible metallic parts, and that are stationary, must also be connected to this bus as well as the service bench itself, if it is made of metallic material. In this way, all these products will be under the same electrical potential, avoiding undesirable leakage currents.



ATTENTION!

Before turning on your equipment, always check that the mains supply voltage is the same as the equipment voltage. If it is not the same, contact the manufacturer or authorized dealer.

The supply voltage of this equipment is 110 V and 127 V (60 Hz) or 220 V (50 or 60 Hz) single-phase, as can be verified on the voltage label affixed to the power cable or as indicated on the nameplate data label, which is located on the back of the equipment (see the figure on this label in item 2.2 of this manual).

Make sure that the voltage of the electrical network where the equipment will be installed is compatible with the voltage indicated on these labels.



ATTENTION!

The equipment power supply network with 127 V or 110 V requires a 25 A circuit breaker and for 220 V a 16 A circuit breaker. The conductor must have a section of 4 mm².

For more details on the rest of the electrical part of the equipment, refer to the electrical diagram in the annexes of the manual.

IMPORTANT

The manufacturer is not responsible for possible direct or indirect damage caused by non-compliance with the rules and instructions presented in this manual.

3.3 Safety Procedures and User Instruction

The professional who sells the equipment must instruct the user on the correct functioning of the equipment and must hand over this instruction manual.

The user must be informed of the necessary safety measures and must respect them, as well as all measures described in this manual.

Your equipment has mechanical protections (see item 1.2 Mechanical Safety). Removing or tampering with these safety components can cause serious risks to the operator's upper limbs.

4. Equipment Use

4.1 Utility

This equipment is exclusively intended for frying food products using oil.

4.2 Commands

Positioned in front of the fryer, the thermostat temperature regulation knob, the signal lamp and the reset button (safety thermostat) can be seen at the top of the panel.

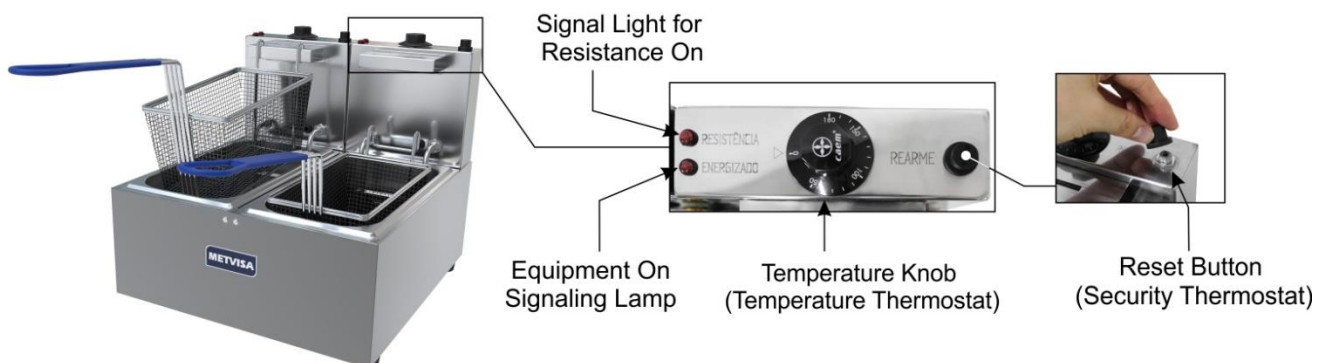

See description of each command below:

- **Temperature Button:** used to regulate the desired temperature, according to the product to be fried.
- **Equipment On Signaling Lamp:** it has the function of indicating when the equipment is energized (on). When unplugging the equipment (turning it off), the lamp will automatically turn off.
- **Signal Light for Resistance On:** it has the function of indicating when the resistance is on. When the selected temperature is reached, the lamp will automatically turn off, turning off the resistance.
- **Reset button:** it is a component of the safety thermostat. It is used to reset the equipment when the temperature thermostat has a failure and/or defect. To activate the button, remove the protective cap by unscrewing it counterclockwise and tighten the button.



ATTENTION!

When you find a defect in the temperature thermostat, immediately take your equipment to an authorized technical assistance center to replace it. After changing the temperature thermostat, reset the equipment by unscrewing the protection cap counterclockwise and pressing the “RESET” button, and on the other thermostat, adjust the temperature again according to the product to be fried.

4.3 Operating Procedures

Before operating the equipment, remove the protective film from the stainless-steel parts and thoroughly clean it, especially the components that will come into contact with food. Clean the equipment with the resistances turned off and the oil at room temperature. Follow the cleaning instructions in item 5 of this manual (below).

After these initial precautions, confirm that the power supply voltage is the same as that of the equipment and that the temperature and safety thermostat bulbs are in perfect condition, that is, they cannot be dented or have any other fault. Faulty thermostats impair the correct functioning of the equipment and the temperature reading, which can cause accidents.



ATTENTION!

Never turn on your equipment with an empty tank or with oil below the minimum level, as this will cause the heating resistance to burn out and damage the entire structure.

The equipment can only be operated after checking that the voltage of the equipment matches that of the electrical supply network.

Check the skewer disassembly and assembly process below:

• **Disassembly:** Before starting the procedure, disconnect the equipment from the main. For a better view of the disassembly procedure, carefully remove the parts according to the sequence below:

1. Disconnect the mains plug;



2. Remove the frying baskets



3. With two hands pull the panel up



4. Remove the tank

Assembly: The assembly procedure is the reverse of the disassembly. As you reassemble each piece, make sure it fits properly before assembling the next item. Pay special attention to the assembly of the panel with the resistance. The two pins, located under the panel, will fit into the two holes in the structure.



After assembly the tank, fit the pins of the resistance panel in the structure holes.

If you find that any parts are hitting with the equipment turned on, it may not have been fitted correctly. In this case, repeat the disassembly / assembly operation and if this is not successful, contact technical assistance.



ATTENTION!

Never turn on the equipment with the tank and panel out of position, as this could cause accidents.

• **Operation:**

1. Add oil to the tank respecting the oil level marking located on the resistance rod. **Note: Type of recommended oil: sunflower, soybean or corn.** Hydrogenated or vegetable fat and cottonseed oil are not suitable for this equipment.

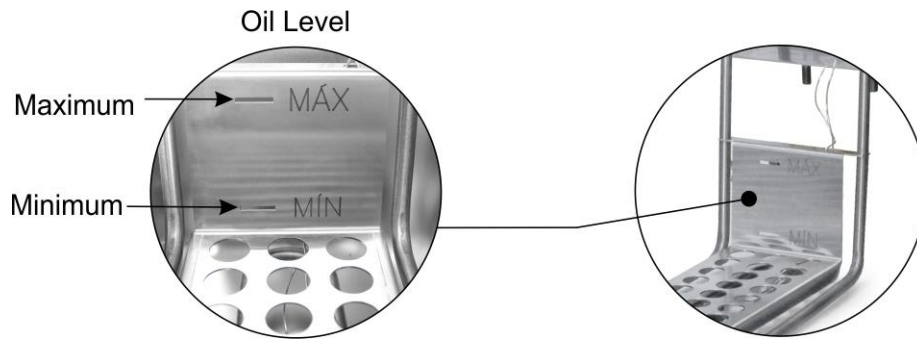

ATTENTION!

There is a danger of fire if the resistance is not submerged in oil.

Always keep the oil level above the resistance or up to the maximum level indicated on the marking, as this prevents accidents and eliminates the risk of burning the resistance.



ATTENTION!

Do not exceed the maximum capacity of the tank. Above that, there is a risk of overflow when placing the basket with the food for frying inside the tank.

2. Connect the power cord to the electrical network;
3. Set the thermostat knob to the desired temperature range, which varies according to the product to be fried. Note: We recommend adjusting the thermostat to a maximum of 180°C, avoiding overheating the oil. When the selected temperature is reached by the thermostat, the indicator light will automatically turn off, turning off the resistance;
4. Add the food to be fried to the basket, and place it in the properly heated oil at the desired temperature;



ATTENTION!

Add the products to be fried slowly and gradually into the basket, thus avoiding the oil bubbling and spilling from the tank. Bubbling will be intense when pouring frozen products.

Attention must be taken to the effect of increased boiling in wet foods and for very large loads.

Never pour water over hot oil, as this could cause a serious accident.

Use suitable PPE and whenever the floor is dirty, clean it.

In case of emergency, remove the plug from the electrical main.

5. Leave the necessary time for the product to fry completely. After that, hang the basket on the support and let the excess oil drain;

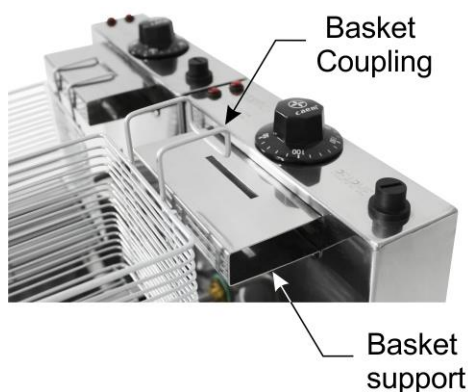

After finishing work, always clean the equipment (see instructions in item 5 of the manual), replace the equipment components in their proper places. After these procedures, the equipment will be available again to restart the operating process.



ATTENTION!

Do not empty the tank with the oil still hot, wait for it to cool completely.

When you have to leave the equipment stopped for an extended period of time, disconnect it from the mains and turn off the circuit breaker.

IMPORTANT

It is recommended not to use the same oil for many operating cycles. It is dangerous to use old oil as it may have a lower flash point and may be more prone to boiling over.

According to ANVISA (National Health Surveillance Agency) instructions, some care must be taken with the oil used in frying. Here are some of them:

- *“The oil must be filtered at each end of use. During the frying of food, especially breaded foods, which tend to release particles from their surface, remove visible residues in the oil with the help of an appropriate utensil”.*
- *“Oil should be discarded when foam and smoke are observed during frying, intense darkening of the oil and food color and perception of uncharacteristic odor and flavor. It is worth remembering that the appearance of smoke is different from the naturally released steam”.*
- *“Oil should not be disposed of in the public sewage system, housewives can pack it in plastic bags or containers and add it to organic waste. As for merchants and fast-food outlets, as they discard a significant amount, it is suggested to contact companies, bodies or entities licensed by the competent body in the environmental area”.*

(Source: ANVISA - Technical Report No. 11, of October 5, 2004; Subject: Oils and Fats Used in Frying).

5. Cleaning and Maintenance

5.1 Cleaning Procedures and Products Used

Your equipment was built with first-line materials, so use it properly and you will obtain great satisfaction. Always keep your equipment clean and well-cared for, which will make it much more durable.

Change the oil whenever necessary. Check the instructions, warnings and recommendations given in item 4.3 of this manual, regarding care with the oil used.

The equipment must be cleaned daily to ensure it works properly and has a longer service life.

To protect the stainless-steel parts, the equipment is supplied with a protective film. Before the first cleaning, remove the film from all parts.



ATTENTION!

Before performing maintenance or cleaning the equipment, make sure the plug is disconnected from the mains. Also, wait for the equipment to completely cool down.



ATTENTION!

Do not use water jet or steam cleaner to clean the equipment.

IMPORTANT

This equipment is not intended to be immersed in water for cleaning.

Follow the instructions below to learn what special care is taken with the equipment

The detachable parts (tank, basket and resistance protection) must be removed from the equipment and washed with lukewarm water and neutral detergent. Clean the corners well, eliminating food residues.

The rest of the equipment should be cleaned as often as possible to prevent food residues from drying out and sticking to the parts. For cleaning, dilute soap or neutral detergent in warm water and apply with a soft cloth. With a cloth moistened with water, rinse and then dry the parts with a dry and soft cloth.

Never use abrasive products or sponges and substances that contain acids or chlorine to clean the metal parts, as they can scratch or damage the surface of the parts causing corrosion points. Do not pour water over the motor and electrical parts for cleaning, otherwise, when turning it on, it may cause an electric shock or even burn the equipment.

IMPORTANT

The manufacturer does not take responsibility for possible direct or indirect damage caused by failure to comply with said standards and other instructions presented in this manual.



ATTENTION!

It is extremely important that the products used for cleaning ensure maximum hygiene and that they are non-toxic.

5.2 Breakdown Maintenance and Procedures

The operator must be instructed to carry out routine inspections, making small adjustments, cleaning and observing signs of breakdowns that may occur. Examples include: checking for strange noises indicating gas leaks; burners that do not light; the non-execution by the equipment to the service to which it is proposed; among others. Actions like these are indispensable to guarantee a longer equipment life.



ATTENTION!

When maintenance is carried out (even if minor adjustments are made), always disconnect the equipment from the mains.

It is recommended that each 6 months be made preventive maintenance, checking and adjusting the loose, cleaning the internal parts, and others. Detecting broke parts or without the correct functionality the worker needs to exchange the parts, always using original parts only.

By carrying out preventive maintenance, the inconvenience of having the equipment stopped when it is most needed is eliminated, the cost of maintenance is reduced and the risk of accidents is reduced.



ATTENTION!

Preventive maintenance requires a trained professional.

Make sure the equipment is disconnected from the mains.

Whenever an item related to the safety of the equipment is removed (such as when performing maintenance), put it back in its proper place and confirm that they are performing their function correctly.

Detecting broke parts or without the correct functionality, please contact the nearest authorized service center.

5.3 Prolonged Interruption in Use of the Equipment

When you have to leave the equipment stopped for an extended period of time, perform a thorough cleaning, including the accessories. It is advisable to protect all parts of the equipment with white petroleum jelly or with suitable products that are commercially available. You must also protect the equipment from dust by covering it with a nylon or other material.

6. Analysis and Troubleshooting

6.1 Problems, possible causes and solutions

IMG quality products are designed with materials and components that guarantee a longer service life for your equipment. However, due to natural wear, improper use or lack of maintenance, the equipment may have irregularities in its operation.

In the following table, you can see possible causes and solutions:

| PROBLEMS | POSSIBLE CAUSES | SOLUTIONS |
|---|---|---|
| Equipment does not turn on. | Lack of electricity | Check if there is energy in the network |
| | | Make sure the power cord is plugged into an outlet. |
| | Equipment voltage different from mains voltage. | Send the equipment to the nearest authorized service station or contact the factory. |
| | Activated safety thermostat. | Press reset button and turn on the equipment again. Send the equipment to the nearest authorized service station or contact the factory. |
| | Other electrical problems (resistance, thermostats, wiring, reset button, bulbs). | Send the equipment to the nearest authorized service station or contact the factory. |
| Equipment turns off in the middle of the use. | Lack of electricity | Check if there is energy in the network |
| | | Make sure the power cord is plugged into an outlet. |
| | Other electrical problems (resistance, thermostats, wiring, reset button, bulbs). | Send the equipment to the nearest authorized service station or contact the factory. |
| | Activated safety thermostat. | Press reset button and turn on the equipment again. Send the equipment to the nearest authorized service station or contact the factory. |
| Equipment smells of burning or smoke. | Equipment voltage different from mains voltage. | Send the equipment to the nearest authorized service station or contact the factory. |
| | Other electrical problems (resistance, thermostats, wiring, reset button, bulbs). | Send the equipment to the nearest authorized service station or contact the factory. |
| | The oil lost its ideal characteristics for frying. | It is recommended not to use the same oil for many cycles of operation. Check some instructions from ANVISA (National Health Surveillance Agency) on page 16. |
| Equipment takes time to fry food. | Other electrical problems (resistance, thermostats, wiring, reset button, bulbs). | Send the equipment to the nearest authorized service station or contact the factory. |

For more information and clarification, contact the Authorized Technical Assistance nearest you. See list of technical assistance on our website: www.metvisa.com.br

7. Useful Life of the Equipment and its Components

The equipment's useful life can vary from 3 to 5 years depending on the proper use, cleaning, maintenance and quality of its components.

Below is the useful life ratio of the main components:

- Resistance: 100.000 uses;
- Temperature Thermostat: 100.000 uses;
- Safety Thermostat: 100.000 uses;
- Electric cables and wires: 25 years;
- Electrical terminals: 8 years.

8. Applicable Standards

The standards applied for the development of the equipment and preparation of this manual are:

- IEC 60335-1;
- IEC 60335-2-37;
- Portaria 148 de 28 de Março de 2022 do INMETRO;
- NR-12 - Portaria 197 de Dezembro de 2010;
- Normas Técnicas Aplicáveis (ABNT NBR, ISO IEC).

9. ANNEXES

Electrical Schematic

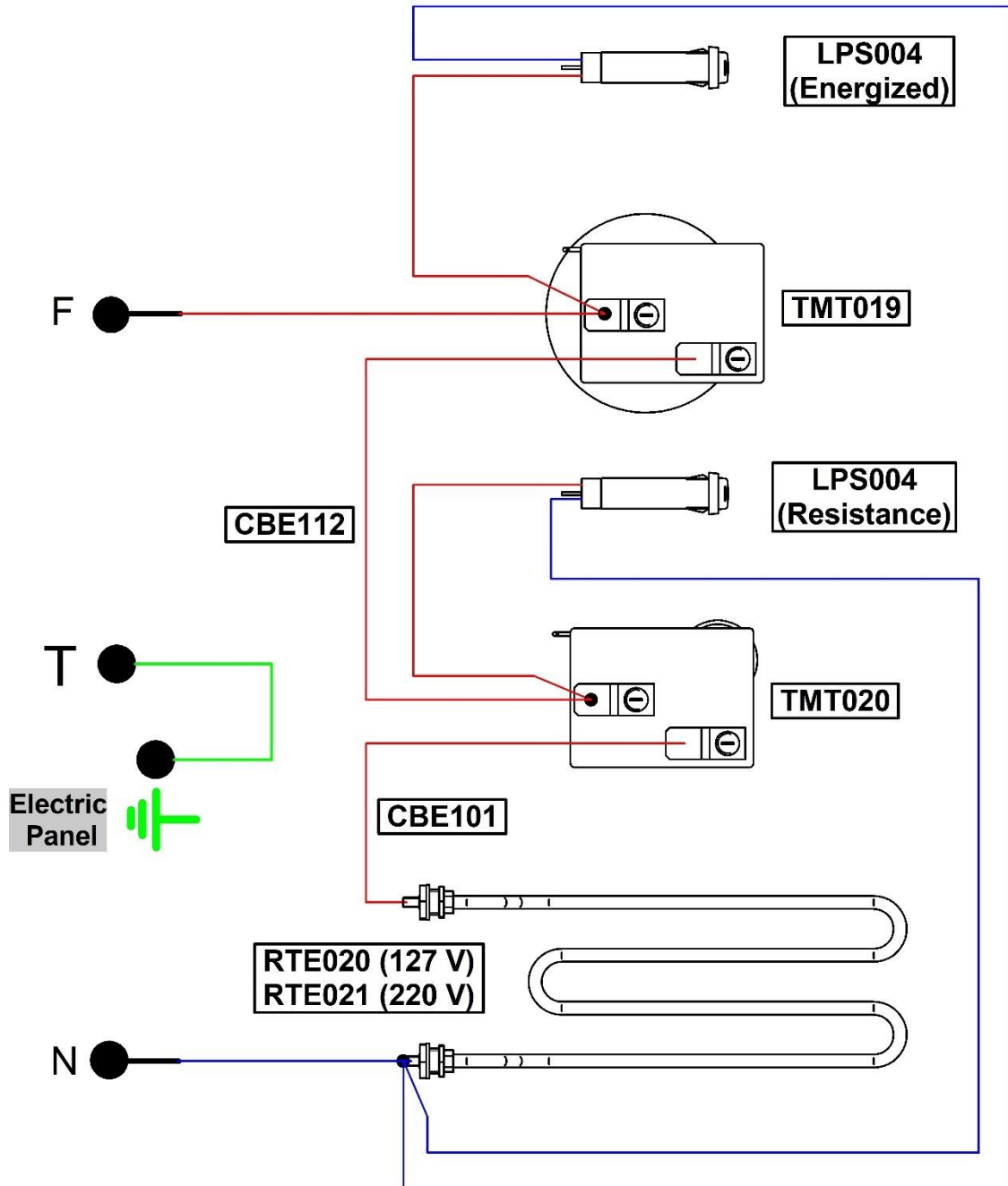

Power cord wiring color legends:

- Phase – Black (on the wiring diagram in red for easy viewing)
- Neutro – Blue or White (varies by supplier)
- Grounding – Green

Exploded View Drawing

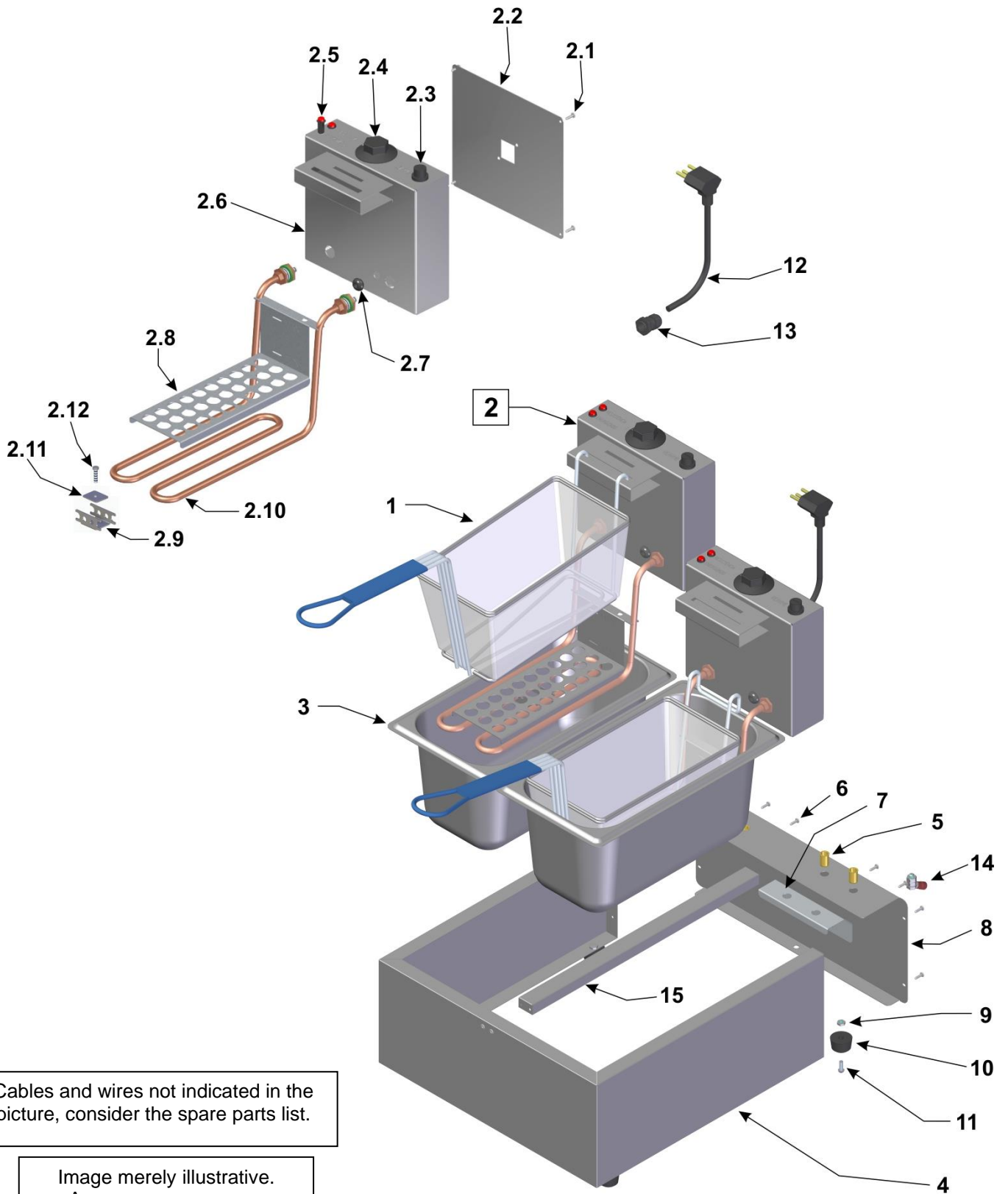

Cables and wires not indicated in the picture, consider the spare parts list.

Image merely illustrative.
Appearances can vary according to the model.

Spare Parts List

| Position | Code | Description | Quantity | Model |
|----------|---------|--------------------------------|----------|-------|
| 1 | CET022 | Frying Basket | 01 | FE3S |
| | | | 02 | FE3D |
| | | | 03 | FE3T |
| 2 | CJT1005 | Panel Set with Resistance 127V | 01 | FE3S |
| | | | 02 | FE3D |
| | | | 03 | FE3T |
| | CJT1006 | Panel Set with Resistance 220V | 01 | FE3S |
| | | | 02 | FE3D |
| | | | 03 | FE3T |
| 2.1 | RBT002 | Rivet | 04 | * |
| 2.2 | TAP185 | Panel Lid | 01 | * |
| 2.3 | TMT020 | Safety Thermostat | 01 | * |
| 2.4 | TMT019 | Temperature Thermostat Set | 01 | * |
| 2.5 | LPS004 | Lamp 127/220 V | 02 | * |
| 2.6 | CJT1000 | Welded Panel | 01 | * |
| 2.7 | BCH039 | Black Lid | 01 | * |
| 2.8 | CRC1297 | Back Lid (Resistance) | 01 | * |
| 2.9 | SBT651 | Bulb Fixing Support | 01 | * |
| 2.10 | RTE020 | Resistance 2500 W - 110/127 V | 01 | * |
| | RTE021 | Resistance 2500 W – 220 V | 01 | * |
| 2.11 | TRV042 | Bulb Lock Plate | 01 | * |
| 2.12 | PCC012 | Stainless Steel Screw | 01 | * |
| 2.13.1 | TCE004 | Terminal FIT (Azul) | 02 | * |
| 2.13.2 | TCE013 | Female Terminal (Yellow) | 02 | * |
| 2.13.3 | CBE101 | Electric Cable | 01 | * |
| 2.13.4 | CBE112 | Electric Cable | 01 | * |
| 2.13.5 | TCE001 | Terminal FIT | 01 | * |
| 3 | BDJ056 | Tank GN 1/3 x 6" (150mm) | 01 | FE3S |
| | | | 02 | FE3D |
| | | | 03 | FE3T |
| 4 | GAB216 | Structure - FE3S | 01 | FE3S |
| | GAB217 | Structure - FE3D | 01 | FE3D |
| | GAB213 | Structure - FE3T | 01 | FE3T |
| 5 | RBT019 | Rivet | 02 | FE3S |
| | | | 04 | FE3D |
| | | | 06 | FE3T |
| 6 | RBT002 | Rivet | 06 | FE3S |
| | | | 12 | FE3D |
| | | | 18 | FE3T |
| 7 | REF116 | Structure Strengthening | 01 | FE3S |
| | | | 02 | FE3D |
| | | | 03 | FE3T |

* Item applicable on all 3L gas fryer models.

Spare Parts List

| Position | Code | Description | Quantity | Model |
|----------|--------|-------------------------------|----------|-------|
| 8 | TAP183 | Structure Side Lid - FE3S | 01 | FE3S |
| | TAP138 | Structure Back Lid - FE3D | 01 | FE3D |
| | TAP184 | Structure Back Lid - FE3T | 01 | FE3T |
| 9 | POS020 | Stainless steel hex nut | 04 | * |
| 10 | PEP004 | Rubber Feet | 04 | * |
| 11 | PRR015 | Machine Screw round | 04 | * |
| 12 | CBE144 | Electric Cable 220 V – Tipo 5 | -- | ** |
| | CBE145 | Electric Cable 127 V – Tipo 5 | -- | ** |
| | CBE002 | Electric Cable 220 V – Tipo 4 | -- | ** |
| | CBE003 | Electric Cable 110 V – Tipo 4 | -- | ** |
| | CBE008 | Electric Cable 220 V – Tipo 2 | -- | ** |
| | CBE021 | Electric Cable 220 V – Tipo 1 | -- | ** |
| 13 | TCE041 | Cable Gland | 01 | * |
| 14 | CJT704 | Grounding Terminal | 01 | * |
| 15 | TAS120 | Structure Traverse | 01 | FE3D |
| | | | 02 | FE3T |

* Item applicable on all 3L gas fryer models.

** The quantity of the piece varies according to the number of tanks
FE3S (01 unit) / FE3D (02 unit) / FE3T (03 unit).

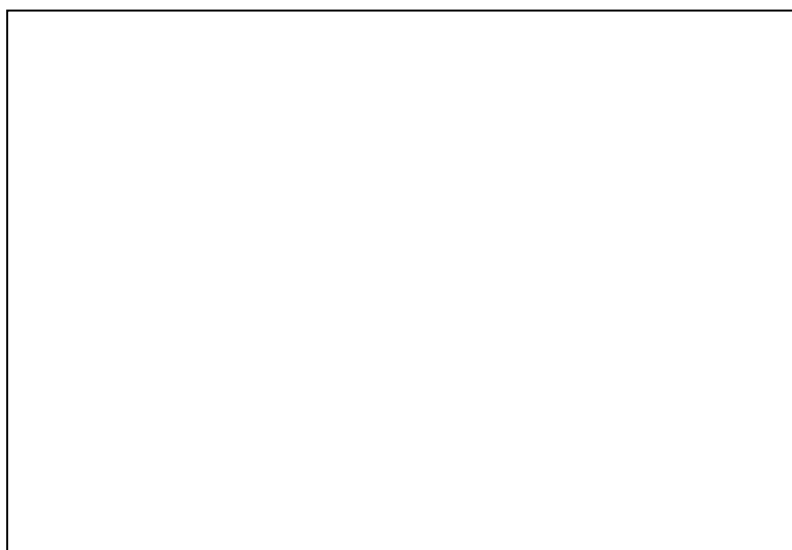

IMG-BRASIL Gastronomy Machinery Industry Ltda.

CNPJ 11.193.347/0001-14 - CREA 131726-3
Road Antônio Heil - KM 23 Nº 5825 - Neighborhood: Limoeiro
ZIP CODE 88352-502 - Brusque - SC - Brazil
Phone/fax. +55 47 3251-5555 - Site: www.metvisa.com.br
Mail: sac@metvisa.com.br - export@metvisa.com.br



Know our complete
line of products.