



INSTRUCTION MANUAL

Installation | Maintenance | Use | Safety

Industrial Stove



Modelo: FGIM2BL



Modelo: FGIM4B

Models

FGIM2B

FGIM2BL

FGIM4B

FGIM4BL

FGIM6B

FGIM6BL

Image merely illustrates.

CONGRATULATIONS,

You have just purchased a IMG-BRASIL equipment, product of the highest quality, safety and efficiency.

Founded in 1989, IMG-BRASIL is a respected company as one of the best and most complete companies in the field of gastronomy equipment manufacturing.

Constant innovation and improvement of its products, using top-of-line raw materials, ensure superior products consumed in Brazil and in more than 25 countries worldwide.

THE RELIABILITY AND CERTAINTY OF A GOOD PRODUCT ARE IN THE NAME

IMG BRASIL PRODUCT MANUFACTURER



IMPORTANT:

**PRODUCT FOR PROFESSIONAL USE. DO NOT USE BEFORE READING THE MANUAL CAREFULLY.
IN CASE OF QUESTIONS, PLEASE CONTACT US::**

IMG-BRASIL Gastronomy Machinery Industry Ltda.

CNPJ 11.193.347/0001-14 - CREA 131726-3

Road. Antônio Heil – KM 23 N° 5825 – Neighborhood: Limoeiro – ZIP CODE 88352-502
Brusque – SC – Brasil

Phone/fax. +55 47 3251-5555 - Site: www.metvisa.com.br

INDEX

1. Safety Information	4
1.1 General Warnings.....	4
1.2 Mechanical Safety	5
2. Technical Characteristics	5
2.1 Main Components.....	5
2.2 Technical Data.....	6
2.3 Supply and Disposal of Equipment Packaging.....	6
3. Installation	7
3.1 Machine Layout	7
3.2 LPG Gas Installation - Recommendations and Care.....	8
3.3 Safety Procedures and User Instruction.....	9
4. Equipment Use	10
4.1 Utility.....	10
4.2 Commands.....	10
4.3 Operating Procedures.....	10
5. Cleaning and Maintenance	13
5.1 Cleaning Procedures and Products Used	13
5.2 Breakdown Maintenance and Procedures.....	14
5.3 Prolonged Interruption in Use of the Equipment.....	15
6. Analysis and Troubleshooting	15
6.1 Problems, possible causes and solutions	15
7. ANEXOS	17
Exploded View Drawing.....	17
Spare Parts	18



ATTENTION!

The characteristics, pictures and figures presented in this manual should be considered for information. IMG BRASIL reserves the right to make such modifications as may be deemed necessary without prior notice.

1. Safety Information

1.1 General Warnings

- Cautions / precautions must be observed when installing, using, maintaining and discontinuing use of this equipment;
- Before carrying out any operation (assembly, use, maintenance and reuse after prolonged use of the equipment), read the manual carefully;
- The equipment must be used by trained personnel familiar with the use and safety regulations described in this manual;
- This equipment is not intended for use by persons (including children) with reduced physical, sensory or mental capacities, or people with lack of experience and knowledge, unless they have received instructions regarding the use of the appliance or are under the supervision of a person responsible for their safety.
- It is recommended that children be supervised to ensure that they are not playing with the equipment;
- In case of rotation of the personnel that will work with the equipment, the new operator must be educated about the standards and the operation of the same one;
- The operator must use the **Adequate PPE** (Personal Protective Equipment). As for example: use appropriated gloves to protect the hand from burning by the structure heating of the equipment or cookware;
- The operator must always be aware of situations that can cause a risk of accidents and avoid them. For example: turn on the gas regulator button without lighting the burner, spreading the gas in the environment causing poisoning, fire and explosion risks;
- After reading and clarifying all doubts, this manual should be carefully stored in an easily accessible location, known to all persons who will operate the equipment and make it available to those who will carry out maintenance for any inquiries. Whenever any questions arise, be sure to check the manual. Do not operate the equipment in any way with doubts;
- In the installation, it is essential to make this manual available to the professionals who will do the same;
- Do not install the equipment near flammable materials;
- Before starting cleaning and any type of maintenance, it is essential that the equipment is at room temperature, with the burners off and the gas pressure regulator closed;
- Periodically check the condition of the hose and the entire gas installation part as well as the internal and external part of the equipment (burners, collecting drawer, gas regulating buttons, etc.).



ATTENTION!

Do not perform repairs on your own. Refer servicing to qualified service personnel. Only use original parts in your equipment.

1.2 Mechanical Safety

- Before operating the equipment, make sure that the gas installation does not leak and if the stove grids (trivets) are correctly assembled.
- Support on the grid only specific products for which the equipment is intended and never place your hands or flammable products, near or directly on the burner and on the table (stainless steel coating).
- When cleaning the equipment, be extremely careful. Turn off the burners and close the gas pressure regulator (gas register). Then wait for the equipment to cool completely. Never place your hands or cleaning products on the burners. For further information on cleaning the equipment, follow the instructions in item 5 of this manual.



ATTENTION!

Always that some item referred to safety be removed from the equipment (for example, for cleaning or maintenance), replace it in place and confirm that it is performing its function correctly.

2. Technical Characteristics

2.1 Main Components

For the equipment described in this manual, safety in use, cleaning, maintenance and maximum hygiene are guaranteed by the design and special design of all parts and also by using stainless steel and other materials suitable for contact with food.

The equipment was built with the following characteristics:

- Table, Structure and front of the drawer made in stainless steel, which has higher corrosion resistance than other steels. It is a material resistant to attack by various corrosive agents;
- Collector drawer, grid and burners made of carbon steel coated with epoxy electrostatic paint for the collector drawer and high temperature paint for the grids and burners. Both finishes are excellent anti-corrosion protections that give greater durability to the parts

See below the main components of the equipment:



2.2 Technical Data

Model	Nominal Measures WidthxHeightxDpht (mm)	Net Weight (approx.) (kg)	Quantity of Burners (units)	Gas Consumption per Burner (kg/h)	Maximum Gas Consumption (kg/h)	Grid Dimension (mm)	Ø Max. Cookware (mm)
FGIM2B	790X220X560	21.3	02	0.30	0.60	300x300	300
FGIM2BL		15.7			1.20		
FGIM4B	790X175X815	30.0	04		1.20		
FGIM4BL		24.6			1.8		
FGIM6B	1188X175X815	45.0	06		1.8		
FGIM6BL		37.0					



ATTENTION!

Features like: model, serial number and voltage of the equipment are provided on the label (figure below).



2.3 Supply and Disposal of Equipment Packaging

The equipment is packed with wood or cardboard to ensure its perfect integrity during transport and is accompanied by the following documents:

- Instruction Manual for Installation. Use, Maintenance and Safety;

IMPORTANT

The packaging components (cardboard, wood, foam, strips, etc.) are products that can be assimilated to municipal solid waste and can be disposed of without difficulty. If the equipment is installed in countries with different standards, dispose of the packaging in accordance with current regulations. Dispose of the product correctly to help protect the environment. For more information on recycling, contact your local authorities, waste disposal service or the shop where you purchased the product.

3. Installation

3.1 Machine Layout

When installing, it is essential to make this manual available to the professionals who will carry it out.

To ensure the correct functioning and safety, the equipment must be positioned in a ventilated environment and on a sufficiently wide, well-leveled, dry and stable support surface, away from heat sources and water taps, and at an average height of 80 cm. Install your equipment leaving a distance of at least 20 cm around it and 1 m in height, so that it has enough space to perform inspection, maintenance, cleaning, use and connection of the gas supply hose.

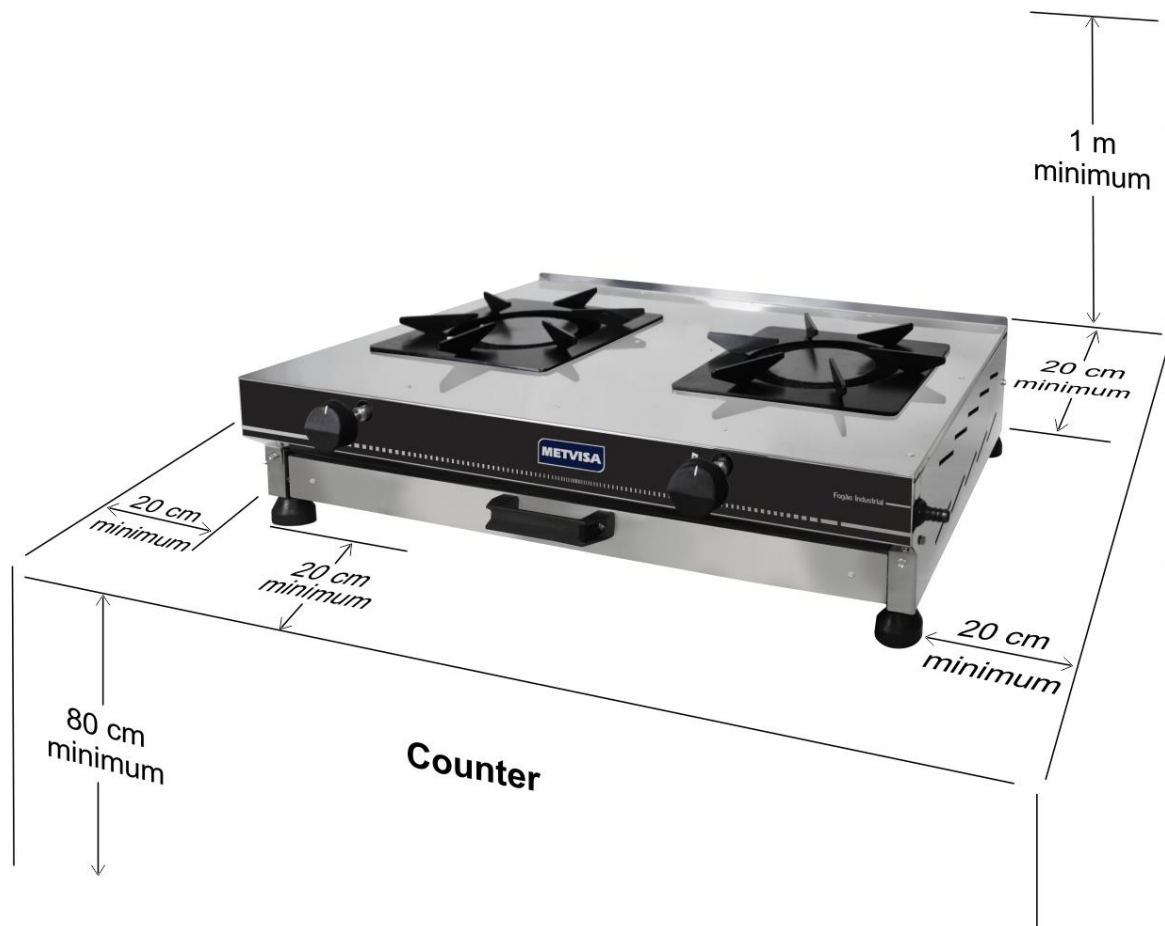



ATTENTION!

This equipment uses LPG gas (liquefied petroleum gas) for its heating, and cannot be installed in closed environments where there is no air renewal, as this gas is highly toxic.

Keep the gas cylinder at least 1.5 m away from electrical outlets, switches, electric keys, or any device subject to a spark or flame, where these in contact with the LPG gas can cause an explosion, causing serious accidents with risk of death to the operator

Do not install the equipment near flammable materials or products.



ATTENTION!

The installation and the place where the equipment will be placed must be in accordance with the Rules for the Prevention of Risks at Work and Safety at Work in Machines and Equipment (Regulatory Norm NR-12).

The manufacturer does not take responsibility for possible direct or indirect damage caused by failure to comply with said standards and other instructions presented in this manual.

3.2 LPG Gas Installation - Recommendations and Care

Check that the place where the equipment will be installed is ventilated and in accordance with the Rules for the Prevention of Risks at Work and Safety at Work on Machines and Equipment (Regulatory Standard NR-12 for Brazil or as current regulatory standard in others country) and periodic inspections by a technician are recommended to ensure that its components are in working condition.



ATTENTION!

The disposition of the equipment must be in an airy place, however that does not have airflow, thus avoiding the extinguishing of the flames in the burners, causing gas leakage.

The gas installation must be done by a qualified technician for this function and observing the safety rules.

The equipment must be installed with the following recommendations and items described below, **HOWEVER NOT PROVIDED WITH THE EQUIPMENT:**

- **Gas Cylinder** - for this equipment the minimum mass is 13 kg (code P13) of LPG (liquefied petroleum gas). The cylinder must comply with ABNT 8460. Check the product's warranty seal. If it has violated, do not install.
- **Pressure Regulator or Gas Record** - use only a low pressure regulator (2.8Kpa) and certified, embossed inscription NBR 8473. When installing the regulator, turn the regulator to the right, until it is firm. Never use tools to perform this operation.
- **Hose** - the model with INMETRO certification (brazilian certification) has the engraving NBR 8613, manufactured in transparent PVC plastic with a yellow stripe. IMG ovens are manufactured with a 3/8"

hose connection. The hose must not pass through or be embedded in walls, and must not make any kind of seam (welding or gluing). Fix the ends only with suitable clamps. Never use wires or tapes. Always check the expiration date of the hose.

IMPORTANT

In addition to the instructions in this manual, it is recommended to also follow the instructions of the manufacturers of cylinders, pressure regulators (gas register) and gas hoses, as these items do not accompany the equipment.



ATTENTION!

Change the pressure regulator every 5 years or when it is defective.

Always use the gas cylinder in an upright position. Never overturn, pour or tilt the cylinder, as the gas may flow into the liquid phase, canceling the pressure regulator function, which can cause serious accidents.

Never install the cylinder close to heated surfaces, and keep the conductive gas hose protected from heat so as not to melt causing fire or other accidents.



ATTENTION!

This equipment operates with LOW PRESSURE GAS. If your supply network has high pressure, have the low pressure outlet valve checked by a technician. If the equipment is switched on at high pressure, the components will be damaged, in addition to creating risks for the operator.

After installation and for your safety, check for gas leaks using only soap and foam. If there is a leak, inform the technician to repeat the installation.

If the leak persists, take the cylinder to a well-ventilated location and inform the dealer or distributor of the cylinder.

IMPORTANT

The manufacturer does not take responsibility for possible direct or indirect damage caused by failure to comply with said standards and other instructions presented in this manual.

3.3 Safety Procedures and User Instruction

The professional who sells the equipment must instruct the user on the correct functioning of the equipment and must hand over this instruction manual.

The user must be informed of the necessary safety measures and must respect them, as well as all measures described in this manual.

Your equipment has mechanical protections (see item 1.2 Mechanical Safety). Removing or tampering with these safety components can cause serious risks to the operator's upper limbs

To avoid accidents and damage to the steel coating, do not support containers directly on the table. Do not use the stove as a work surface or support for activities other than cooking.



ATTENTION!

Hot oil or fat is flammable, use them with care. In the event of a fire in hot oil or fat, turn off the gas regulator buttons (knob) and smother the flames with a pan lid or a wet cloth. Never pour water to put out the flames, as the water in contact with the oil or fat spreads, which can cause burns.

4. Equipment Use

4.1 Utility

This equipment is intended exclusively for cooking food for professional use.

4.2 Commands

The equipment consists of gas regulating buttons (fire level) on the front. Check the adjustment positions in the following image:

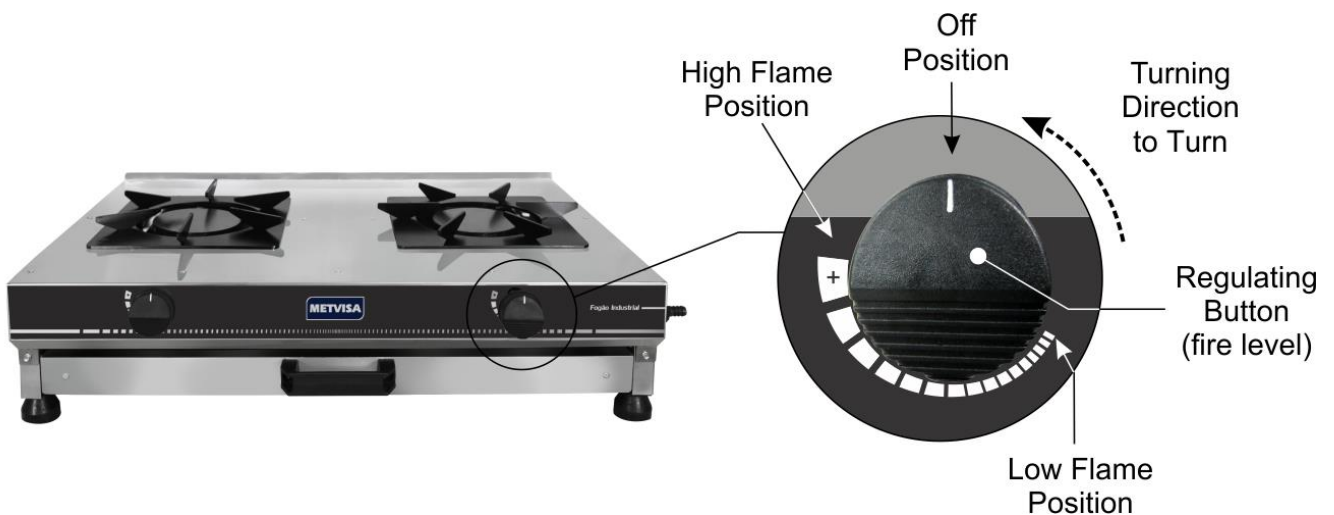

4.3 Operating Procedures

Before operating the equipment, make perfect cleaning, especially on the table and on the grids. If your equipment is supplied with a protective film on the stainless steel parts, it must be removed before use. Clean the equipment with the burners off, the gas pressure regulator (gas register) closed and the equipment at room temperature. Follow the cleaning instructions in item 5 of this manual (below).

After these initial precautions, make sure that the gas hose connections are correctly fixed and that there are no leaks. Also check that the cooker grids (trivets) are correctly assembled and that the collecting drawer is properly fitted, preventing food from falling on the countertop.



ATTENTION!

For the first use of the equipment, it is necessary to cure the paint on the burners. To do this, turn on the empty equipment for a minimum period of 10 minutes. Follow the lighting instructions in the operation item below.

During the paint curing procedure, odor and smoke will be released due to the burning of the paint.

Turn off the equipment and wait until the equipment is at room temperature. After that your equipment will be available for use.

• **Operation:** The equipment can only be operated after checking the correct disposition of the equipment, as instructed in item 3.1, and after following the care and recommendations of the gas installation, according to the guidelines in item 3.2.

Check the following operating instructions:

1. The equipment is turned on manually. Open the gas pressure regulator (gas register);
2. Press the gas regulator button and turn to the on position;
3. For correct and safe ignition, use an automatic type igniter. With the lighter in hand, place the tip up to 1 or 2 cm from the burner for lighting;

IMPORTANT

The automatic igniter does not come with the equipment, so always check the instructions for use on the packaging, which may vary depending on the make and model.

4. Repeat the procedure for lighting each burner;
5. Adjust the fire level on the gas control button and observe the quality of the flame. The ideal flame should be blue.



ATTENTION!

After opening the gas valve, quickly light the burners, as the gas is already spreading in the air.

Light one burner at a time and make sure that the burners are completely lit.

In case of failure to ignite and you can smell gas in the environment, do not ignite.

Wait a few minutes for the air to renew in the room, and then repeat the lighting process.

IMPORTANT

The probable vapors in the first use should not be considered defects.

Use pans of an appropriate diameter that fully cover the flames (maximum diameter of 30 cm) and with a flat bottom to properly support the grids.

The use of pans with a diameter greater than that specified may cause damage to the equipment and decrease its efficiency.

Keep the pan centered on the grill and covered, this reduces cooking time promoting gas savings.

Never use two burners to heat a large pot or container.

Avoid leaving the pot handles facing away from the stove.

Use only heat resistant utensils.

6. After igniting, support the pan on the grid (trivet);
7. It is advisable that, as soon as a liquid begins to boil, the flame be reduced enough to maintain boiling;



ATTENTION!

Always keep the collection drawer attached to the stove and empty it constantly, thus avoiding excess waste and contamination.

8. After finishing the work, turn off the burner by turning the gas regulator button to the off position and remove the pan. Close the gas pressure regulator (gas register).
9. Wait for the equipment to reach room temperature before cleaning.



ATTENTION!

After finishing the work step and switching off the burners, close the gas pressure regulator (register), because if it happens to be open, the pressure exerted on the hose may damage it or rupture, causing fire or other accidents.



ATTENTION!

During the operation, hot vapors and splashes of overheated oil or fat may be expelled. Always use PPE's (Personal Protective Equipment).

IMPORTANT

Do not start the cooking process if there are food residues on the collection table or drawer, this can cause contamination with bacteria.

5. Cleaning and Maintenance

5.1 Cleaning Procedures and Products Used

Your machine was built with first-line materials, so use it properly and you will obtain great satisfaction. Always keep your machine clean and well-cared for, which will make it much more durable.

Daily cleaning of the machine must be carried out for good operation and durability. Preventing the accumulation of bacteria which can cause contamination in food.

If your equipment is supplied with a protective film on the stainless steel parts, it must be removed before the first cleaning.



ATTENTION!

Before carrying out maintenance or cleaning, make sure that the equipment has the burners off, the pressure regulator (gas) closed and at room temperature.



ATTENTION!

Do not use water jet to clean the machine.

IMPORTANT

This machine is not intended to be immersed in water for cleaning. Follow the instructions below to learn the parts that can be immersed and what special care is taken with the other parts.

Dismountable parts (collecting drawer and support grids) must be removed from the equipment and washed with water and soap or neutral detergent. Clean the corners thoroughly, eliminating cooking residues.

When cleaning the table and structure, dilute in warm water, soap, neutral detergent, or ammonia-based remover and apply with a soft cloth. With a cloth moistened with water, rinse and with a dry, soft cloth dry the parts immediately to avoid staining.

Never use abrasive products (sapolium, brushes or steel wool) and substances that contain acids or chlorine on any stainless steel surface, as it will damage the parts and cause points of corrosion.

Never use aluminum foil or similar to cover the stainless steel table, avoiding stains and yellowing.



ATTENTION!

It is extremely important that the products used in cleaning ensure maximum cleanliness and are not toxic.

5.2 Breakdown Maintenance and Procedures

The operator must be instructed to carry out routine inspections, making small adjustments, cleaning and observing signs of breakdowns that may occur. Examples include: checking for strange noises indicating gas leaks; burners that do not light; the non-execution by the equipment to the service to which it is proposed; among others. Actions like these are indispensable to guarantee a longer equipment life.



ATTENTION!

When maintenance is carried out (even if minor adjustments are made), always check that the equipment has the burners off, the pressure regulator (register) of the gas closed and the equipment be at room temperature.

It is recommended that each 6 months be made preventive maintenance, checking and adjusting the loose, cleaning the internal parts, and others. Detecting broke parts or without the correct functionality the worker needs to exchange the parts, always using original parts only.

By carrying out preventive maintenance, the inconvenience of having the machine stopped when it is most needed is eliminated, the cost of maintenance is reduced and the risk of accidents is reduced.

Follow the equipment maintenance and adjustment recommendations:

- Change the gas pressure regulator (register) every 5 years or when it is defective;
- Check the expiration date of the gas hose and follow other instructions as recommended by the manufacturer;
- After the end of the use, keep the pressure regulator (register) of the gas closed, avoiding pressure in the hose;
- The gas outlet holes in the burners must always be unobstructed. If they become clogged, use a specific needle to clean stove nozzles;



ATTENTION!

Preventive maintenance requires a trained professional.

Always that some item referred to safety be removed from the equipment (for example, for cleaning or maintenance), replace it in place and confirm that it is performing its function correctly.

Detecting broke parts or without the correct functionality, please contact the nearest authorized service center.

5.3 Prolonged Interruption in Use of the Equipment

When you have to leave the equipment stopped for an extended period of time, perform a thorough cleaning, including the accessories. It is advisable to protect all parts of the equipment with white petroleum jelly or with suitable products that are commercially available. You must also protect the equipment from dust by covering it with a nylon or other material.

6. Analysis and Troubleshooting

6.1 Problems, possible causes and solutions

IMG quality products are designed with materials and components that guarantee a longer service life for your equipment. However, due to natural wear, improper use or lack of maintenance, the equipment may have irregularities in its operation.

In the following table, you can see possible causes and solutions:

PROBLEMS	POSSIBLE CAUSES	SOLUTIONS
Burners do not light	Lack of gas.	Check if there is gas in the cylinder, if the gas cylinder register is open, if the gas hose is connected and if the gas regulator is open.
	Damaged or broken pressure regulator (register).	Contact or send the equipment to an Authorized Technical Assistance.
	Clogged burner.	Unclog burner holes using a needle for cleaning stove nozzles, if not resolved, send the equipment to the nearest authorized service station or contact the factory.
	Lack of gas.	Below, check the possible causes and solutions for gas leak (page 16).
Yellow flame, generating equipment soot	Problem in mixing gas with oxygen.	Assess whether the gas in the cylinder is exhausted.
Lack of gas	Damaged, loose or broken pressure regulator (register).	Send equipment to the nearest authorized service station or contact the factory, as there are risks of accidents.
	Injector nozzle out of position.	Send equipment to the nearest authorized service station or contact the factory, as there are risks of accidents.
	Defective gas cylinder.	Check if has gas leakage using only soap foam. If there is a leak, inform the technician to repeat the installation. If the leak persists, take the cylinder to a well-ventilated location and inform the dealer or distributor of the cylinder.
	Gas cylinder installed in the horizontal position.	Install the cylinder in a vertical position. Never overturn, pour or tilt the cylinder, as the gas may flow into the liquid phase, canceling the pressure regulator function, which can cause serious accidents.
Difficulty regulating the flame	Damaged or broken pressure regulator (register).	Send equipment to the nearest authorized service station or contact the factory, as there are risks of accidents.
	Old or broken pressure regulator (register).	To replace the button contact or send the equipment to an Authorized Technical Assistance.
Lack of gas during operation	Lack of gas.	Check if there is gas in the cylinder, if the gas cylinder register is open, if the gas hose is connected and if the gas regulator is open.
	Pressure regulator (register) broken by collision.	Send equipment to the nearest authorized service station or contact the factory, as there are risks of accidents.

For more information and clarification, contact the Authorized Technical Assistance nearest you. See list of technical assistance on our website: www.metvisa.com.br

7. ANEXOS

Exploded View Drawing

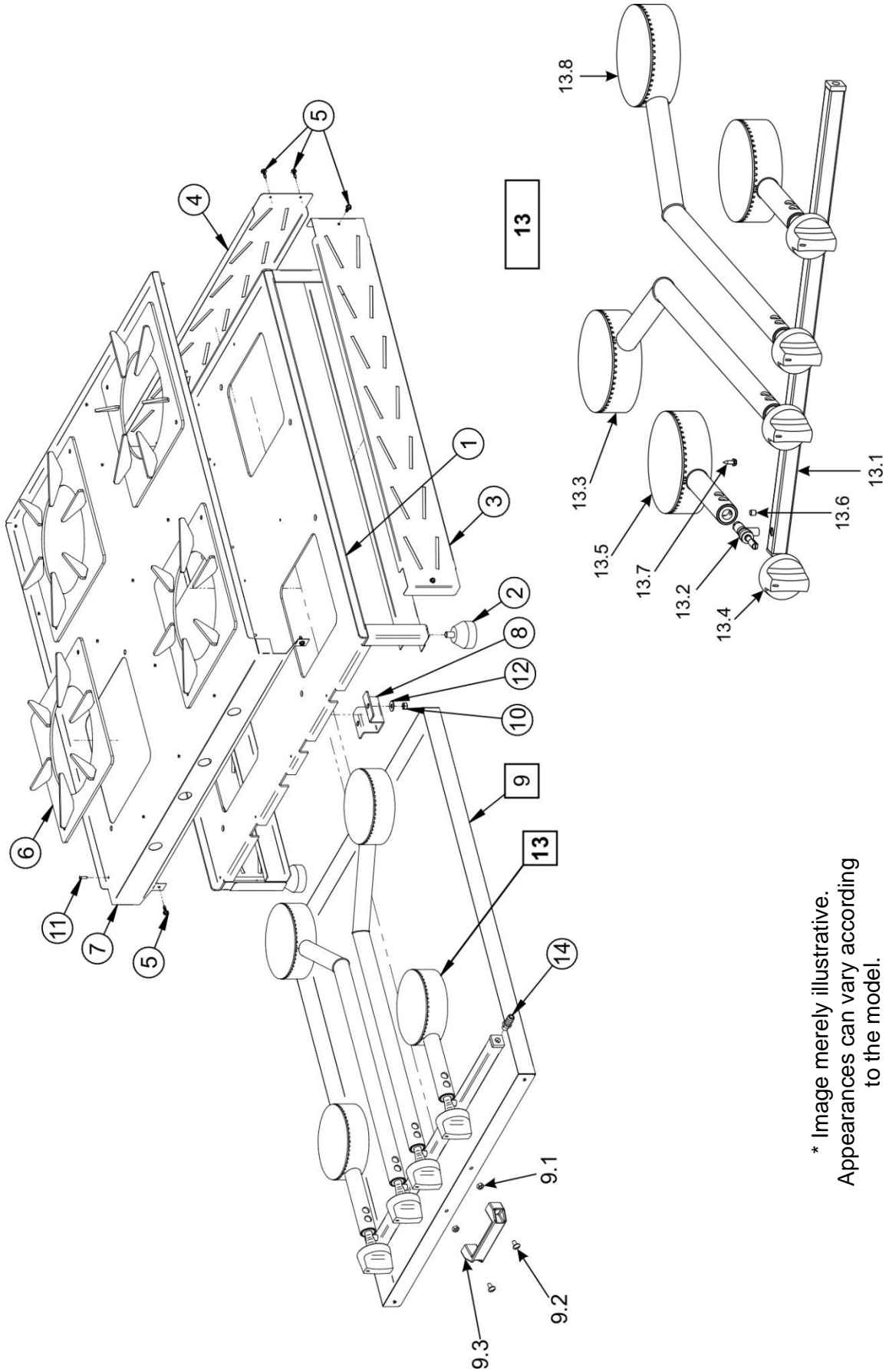

* Image merely illustrative.
Appearances can vary according
to the model.

Spare Parts

Position	Code	Description	Quant.	Model
1	ETR143	Stove Structure	1	FGIM2B/L
	ETR149			FGIM4B/L
	ETR159			FGIM6B/L
2	PEP019	Rubber Foot	4	*
3	REF037	Side Coating	2	FGIM2B
	REF130			FGIM4B
				FGIM6B
4	REF040	Back Coating	1	FGIM2B
	REF126			FGIM4B
	REF128			FGIM6B
5	PRA008	Stainless Steel Hexagon Screw	10	FGIM2B/4B/6B
6	CJT984	Grid	2	FGIM2B/L
			4	FGIM4B/L
			6	FGIM6B/L
7	CRC1276	Finishing Plate	1	FGIM2B
	CRC1392			FGIM4B
	CRC1541			FGIM6B
8	SBT498	Burner Support	2	FGIM2B/L
			6	FGIM4B/L
			9	FGIM6B/L
9	CJT983	Collecting Drawer	1	FGIM2B
	CJT1080			FGIM4B
	CJT1237			FGIM6B
9.1	POS021	Stainless Steel Hexagon Nut	2	FGIM2B/4B/6B
9.2	PRR009	Parafuso Máq. Red.	2	FGIM2B/4B/6B
9.3	ACA009	Plastic Handle	1	FGIM2B/4B/6B
10	POS018	Hexagon Nut	4	FGIM2B/L
			12	FGIM4B/L
			17	FGIM6B/L
11	RBT002	Rivet	14	FGIM2B/L
			21	FGIM4B/L
			29	FGIM6B/L
12	ARL004	Flat Washer	4	FGIM2B/L
			12	FGIM4B/L
			17	FGIM6B/L
13	CJT998	Front Burner	1	FGIM2B/L
	CJT1081			FGIM4B/L
	CJT1238			FGIM6B/L

FGIM2B/L – Applicable item for models FGIM2B e FGIM2BL.

FGIM4B/L – Applicable item for models FGIM4B e FGIM4BL.

FGIM6B/L – Applicable item for models FGIM6B e FGIM6BL.

FGIM2B/4B/6B – Applicable item for models FGIM2B, FGIM4B and FGIM6B.

* Item applicable to all stove models described in this manual.

Spare Parts

Position	Code	Description	Quant.	Model
13.1	CJT985	Gas Tube Set	1	FGIM2B/L
	CJT1083			FGIM4B/L
	CJT1239			FGIM6B/L
13.2	CJT098	Assembly Gas Valve	2	FGIM2B/L
			4	FGIM4B/L
			6	FGIM6B/L
13.3	BAL025	Left Rear Welded Burner	1	FGIM4B/L
			2	FGIM6B/L
13.4	BOT053	Gas Regulator Button	2	FGIM2B/L
			4	FGIM4B/L
			6	FGIM6B/L
13.5	BAL015	Complementary Burner Nozzle	2	FGIM2B/L
	BAL024		2	FGIM4B/L
			3	FGIM6B/L
13.6	PRN004	Screw Allen S/C	2	FGIM2B/L
			4	FGIM4B/L
			6	FGIM6B/L
13.7	PRA008	Stainless Steel Hexagon Screw	2	FGIM2B/L
			4	FGIM4B/L
			6	FGIM6B/L
13.8	BAL026	Right Rear Welded Burner	1	FGIM4B/L
				FGIM6B/L
14	CNX055	Gas Connection 1/8 NPT for Socket (Hose 3/8")	1	*
	CNX053	Gas Connection 1/8 NPT for 1/2 NPT		*

FGIM2B/L – Applicable item for models FGIM2B e FGIM2BL.

FGIM4B/L – Applicable item for models FGIM4B e FGIM4BL.

FGIM6B/L – Applicable item for models FGIM6B e FGIM6BL.

FGIM2B/4B/6B – Applicable item for models FGIM2B, FGIM4B and FGIM6B.

* Item applicable to all stove models described in this manual.

IMG BRASIL PRODUCT MANUFACTURER



IMG-BRASIL Gastronomy Machinery Industry Ltda.

CNPJ 11.193.347/0001-14 - CREA 131726-3

Rod. Antônio Heil – KM 23 Nº 5825 – Limoeiro

CEP 88352-502 - Brusque – SC – Brazil

Phone/fax. +55 47 3251-5555 - Site: www.metvisa.com.br

E-mail: sac@metvisa.com.br - export@metvisa.com.br - export2@metvisa.com.br



Discover our complete
line of products.