



INSTRUCTION MANUAL

Installation | Maintenance | Use | Safety

Tilting Blender

Models

LQL.19

LQL.25



Model: LQL.19

Image merely illustrates.

CONGRATULATIONS,

You have just purchased a IMG-BRASIL equipment, product of the highest quality, safety and efficiency.

Founded in 1989, IMG-BRASIL is a respected company as one of the best and most complete companies in the field of gastronomy equipment manufacturing.

Constant innovation and improvement of its products, using top-of-the-line raw materials, ensure superior products consumed in Brazil and in more than 25 countries worldwide.

THE RELIABILITY AND CERTAINTY OF A GOOD PRODUCT ARE IN THE NAME

IMG BRASIL PRODUCT MANUFACTURER



IMPORTANT:

PRODUCT FOR PROFESSIONAL USE. DO NOT USE BEFORE READING THE MANUAL CAREFULLY. IN CASE OF QUESTIONS, PLEASE CONTACT US:

IMG-BRASIL Indústria de Máquinas para Gastronomia Ltda.

CNPJ 11.193.347/0001-14 - CREA 131726-3

Rod. Antônio Heil – KM 23 Nº 5825 – Bairro: Limoeiro – CEP 88352-502 - Brusque – SC – Brasil

Phone/fax. +55 47 3251-5555 - Website: www.metvisa.com.br

E-mail: sac@metvisa.com.br - vendas@metvisa.com.br

CONTENTS

1. Safety Information	4
1.1 General Warnings.....	4
1.2 Mechanical Safety	5
1.3 Electrical Safety.....	6
2. Technical Features	6
2.1 Main Components.....	6
2.2 Technical Data.....	8
2.3 Supply and Disposal of Appliance Packaging	8
3. Installation	9
3.1 Equipment Layout.....	9
3.2. Electrical Connection	10
3.3 Safety Measures and User Instruction	11
4. Use of the Appliance	11
4.1 Utility.....	11
4.2 Commands	12
4.3 Operating Procedures.....	12
5. Cleaning and Maintenance	14
5.1 Cleaning Procedures and Products Used	14
5.2 Maintenance and Behavior in Case of Breakdowns	16
5.3 Prolonged Interruption of Appliance Use.....	17
6. Analysis and Troubleshooting	17
6.1 Problems, possible causes and solutions	17
7. Useful life of the Appliance and its Components	18
8. ANNEXES	19
Electrical Schema - LQL.19/25 Voltage 110 V or 220 V 60 Hz.....	19
Electrical Schema - LQ.19/25 Voltage 220 V 50 Hz.....	20
Exploded Drawing	21
Replacement Parts	22



ATTENTION!

The characteristics, pictures and figures presented in this manual should be considered for information purposes. IMG BRASIL reserves the right to make such modifications as may be deemed necessary without prior notice.

1. Safety Information

1.1 General Warnings

- Cautions / precautions must be observed when installing, using, maintaining and discontinuing use of this appliance;
- Before carrying out any operation (assembly, utilization (use), maintenance and reuse after prolonged use of the equipment), read the manual carefully;
- The equipment must be used by trained personnel familiar with the use and safety standards described in this manual;

This appliance is not intended for use by persons (including children) with reduced physical, sensory or mental capacities, or people with lack of experience and knowledge, unless they have received instructions regarding the use of the appliance or are under the supervision of a person responsible for their safety;

- It is recommended that children be supervised to ensure that they are not playing with the equipment;
- In case of change of the personnel that will work with the equipment, the new operator must be educated about the standards and the operation of the same one;
- The operator must use the **Adequate PPE's** (equipment for individual safety). As for example: use touches the hair avoiding that they lock in the moving parts of the machine;
- The operator must always be aware of situations that can cause a risk of accidents and avoid them. For example: avoid working with loose uniform sleeves, where they can lock in moving parts, causing accidents;
- After being held to read and answered all the questions, this manual must be stored carefully in place of easy access, known by all the people who will operate the equipment and made available for the people who carry out maintenance, to any queries. Whenever any questions arise, be sure to check the manual. Do not operate the equipment in any way with doubts;
- In the installation, it is essential to make this manual available to the professionals who will do the same;
- Never place hands, fingers or objects inside the cup while the appliance is on, as this could cause an accident;
- Before starting cleaning and any maintenance, it is essential to disconnect the appliance from the power grid;
- Periodically check the condition of the cables and electrical parts;
- Never connect the appliance with the cup uncovered, and do not tilt the cup while the appliance is in operation;
- Do not leave the equipment switched on without supervision.



ATTENTION!

Do not perform repairs on your own. Refer to the technical service authorized by the manufacturer. Use only original parts in your appliance.

1.2 Mechanical Safety

- Only insert the specific products for which the appliance is intended and never place your hands, fingers or objects in the cup with the appliance turned on, as this will cause an accident.
- Before turning on the appliance, make sure that the tilt support is locked with the handle (cup in upright position).



The appliances described in this manual comply with the mechanical hazard regulations. Safety is obtained with:

- **Mechanical design** that makes it impossible for hands to access electrical parts and rotating cutting parts;
- **Lid** that prevents splashing out of the cup and protects the operator when processing food;
- **Motor** with opening for ventilation of reduced size, preventing the access with the hands to the electric parts;
- The appliance has a **handle** to lock the tilt support, ensuring that the cup does not tilt during food processing.

For component viewing, see item 2.1 (Main Components - page 7) of this manual.



ATTENTION!

Whenever any item regarding the safety of the equipment (such as cleaning or maintenance) is removed, reset it and confirm that it is performing its function correctly.

1.3 Electrical Safety

- Periodically check the condition of the cables and electrical parts;
- If the power cord is damaged, it must be replaced with a new one. The exchange must be made by the manufacturer, authorized agent or a qualified person in order to avoid risk;
- Do not use a water jet as this may cause electric shock. To clean your appliance, follow the instructions in item 5 of this manual;
- Do not work with the appliance in humid places, or with wet clothes and shoes. Wear proper footwear, this will prevent electric shocks and even death;
- Place the appliance on a firm, dry and level surface;
- Do not use extension cords or adapters with several other appliances connected to them. This may cause fire or over load;
- Never carry out any maintenance, adjustment or disassembly of the equipment connected to it. For such procedures, make sure it is turned off by removing the plug from the electrical outlet.

Components used for safety against electrical hazards have been selected in accordance with applicable safety standards. Given the perfect insulation of all the electrical parts and the excellent resistance of all the materials used, this unit is able to carry out the works to which they are proposed.



ATTENTION!

Whenever any item regarding the safety of the equipment (such as cleaning or maintenance) is removed, reset it and confirm that it is performing its function correctly.

2. Technical Features

2.1 Main Components

For the equipment described in this manual, safety in use, cleaning, maintenance and maximum hygiene are guaranteed by the design and special project for all parts, as well as by using stainless steel and other materials suitable for contact with food.

The appliance was built with the following features:

- Lid made of non - toxic plastic (polyethylene - PE). Material resistant to citric acid (found in lemon and orange juice), is easy to maintain, hygienic and resistant to corrosion.
- Cup manufactured in stainless steel, which resists the attack of several corrosive agents, such as the majority of the organic acids, organic substances in general, alkalis, oxy-salts, etc..

Note: stainless steel is attacked by sulfuric acid, and also cannot withstand hydrochloric acid, diluted sulfuric acid, chlorides and halides in general.

- Easel and tilt support, both in carbon steel coated with epoxy paint, an excellent anti-corrosion protection.
- The blades are made of 304 stainless steel and undergo a hardening process which increases the hardness of the steel and its wear resistance. Very resistant to aggressive agents such as fruit and vegetable juices, some mild acids and alkalies, water vapor free of contaminants, etc.

See the following for the main components of the appliance:



Note: for the exploded view drawing with spare parts list, see the annexes.

2.2 Technical Data

Model	Nominal Operating Measures WidthxHeightxDepth (mm)	Net Weight (kg)	Voltage (V)	Rated Current (A)	Electric Cable (Cod. IMG)	Cable Gland Support (Cod. IMG)	Capacity (L)
LQL19110M604	380x1025x855*	19.3	110	12	CBE002	SBT439	19
LQL19220M501	380x1025x855*	19.3	220	6.5	CBE020	SBT513	
LQL19220M502	380x1025x855*	19.3	220	6.5	CBE007	SBT513	
LQL19220M503	380x1025x855*	19.3	220	6.5	CBE010	SBT513	
LQL19220M504	380x1025x855*	19.3	220	6.5	CBE001	SBT513	
LQL19220M604	380x1025x855*	19.3	220	7.0	CBE001	SBT513	
LQL25110M604	380x1120x920*	20.5	110	16.4	CBE003	SBT439	25
LQL25220M501	380x1120x920*	20.5	220	9.9	CBE021	SBT439	
LQL25220M502	380x1120x920*	20.5	220	9.9	CBE008	SBT439	
LQL25220M504	380x1120x920*	20.5	220	9.9	CBE002	SBT439	
LQL25220M604	380x1120x920*	20.5	220	9.5	CBE002	SBT439	
LQL25220M503	380x1120x920*	20,5	220	9,9	CBE011	SBT439	

* Bottom measurement indicated with the cup tilted (inclined horizontally at 90°). And the height with the cup in the vertical.

Noise level: 80 dB.



ATTENTION!

Characteristics such as: model, serial number and voltage of the equipment are provided on the label (figure below). Before installation, check that the supply voltage of the appliance complies with that of the power grid.

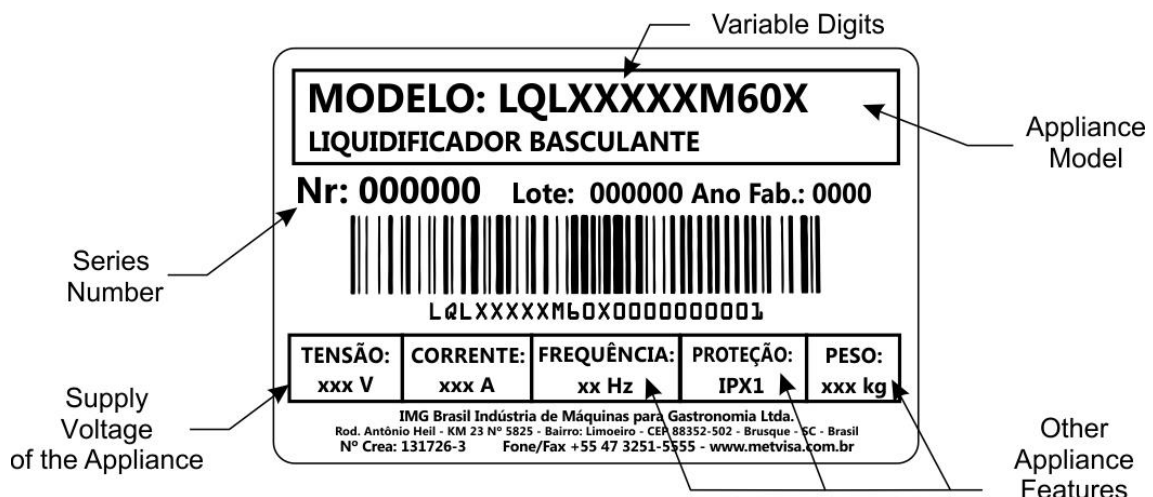

2.3 Supply and Disposal of Appliance Packaging

The appliance is packed with wood or cardboard to ensure that it is perfectly intact during transport and is accompanied by the following document:

- Instruction Manual for Installation, Use, Maintenance and Safety;

IMPORTANT

The packaging components (cardboard, wood, foam, strips, etc.) are products that can be assimilated to solid urban waste and can be disposed of without difficulty. If the equipment is installed in countries with different standards, dispose of the packaging in accordance with current regulations. Dispose of the product correctly to help protect the environment. For more information on recycling, contact your local authorities, waste disposal service or the shop where you purchased the product.

3. Installation

3.1 Equipment Layout

The connection to the mains and the arrangement for operation must be carried out by a qualified professional. Check that the voltage of the equipment matches the power grid.

During installation, it is essential to make this manual available to the professionals who will carry it out.

To ensure correct operation and safety, the appliance should be positioned over a sufficiently wide, level, dry and stable floor area, away from heat sources, water taps and where there is no heavy human traffic. Install your appliance leaving a free area on top of the appliance and a distance of at least 1 m at the rear and 50 cm at the sides and front, so that there is enough space for inspection, maintenance, cleaning and use.

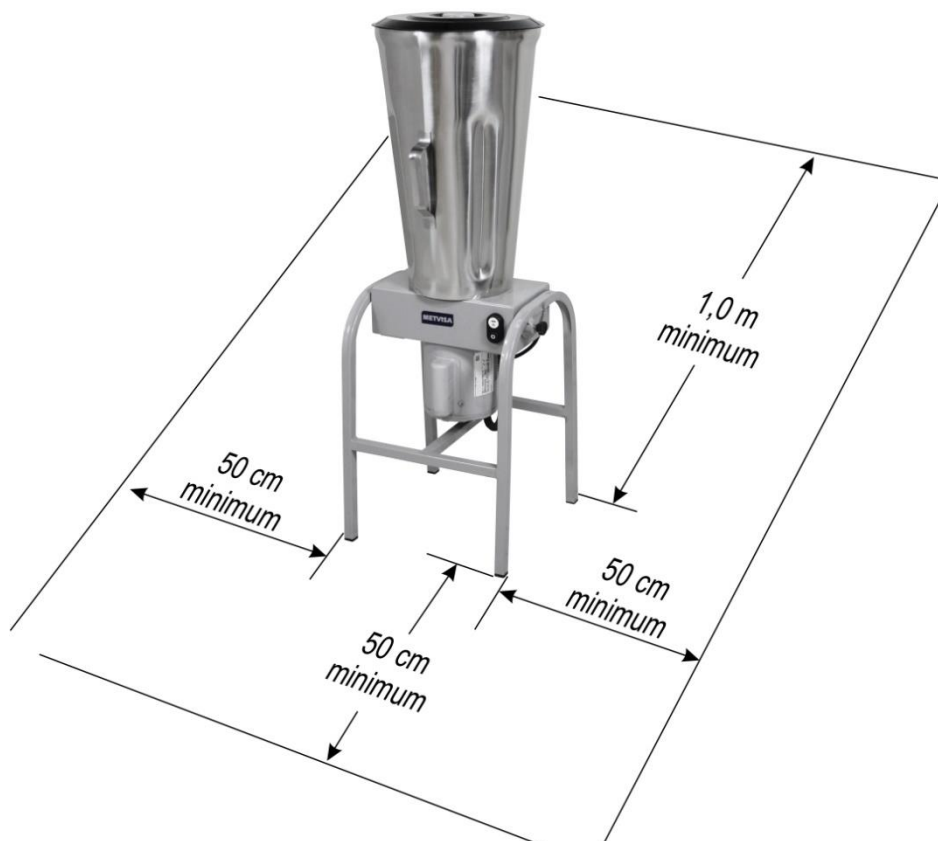



ATTENTION!

The installation and location of the appliance must be in accordance with the regulations on the prevention of risks and safety at work (regulatory standard in force in your country).

The manufacturer will not be responsible for possible direct or indirect damage caused by non-compliance with said standards and other instructions presented in this manual.

3.2. Electrical Connection

The equipment comes with a power cord to be plugged into an electrical outlet. If the power cord is damaged, it must be replaced with a new one. The exchange must be made by the manufacturer, authorized agent or a qualified person in order to avoid risk.

The type of plug of the power cord varies by country. The installation of the equipment must be carried out by a qualified technician for this role and in accordance with the current regulations of the country, especially with regard to the ground connection (if applicable).

An equipotential ground terminal, located on the easel, is supplied with the appliance (image below).

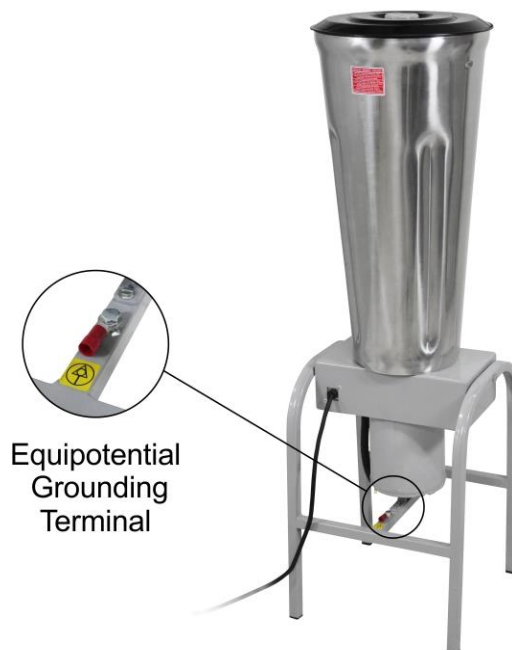

The post identified in the figure below is an additional protection for the grounding that is provided in the mains, it must be connected to a grounding terminal bar, regardless of the connection to the mains, and other products that have accessible metallic parts. And which are stationary, must also be connected to this bus as well as the service bench itself, in case it is of metallic material. As such, all these products will be under the same electrical potential avoiding undesirable leakage current.

All models of the appliances described in this manual are single-phase and have a single voltage, wither 110 V or 220 V. If you need to change the voltage on your appliance, contact the manufacturer or an authorized dealer.



ATTENTION!

Before connecting your appliance, always check that the supply voltage of the network is the same as the voltage of the appliance.

The supply voltage of the appliances is 110 V (60 Hz) or 220 V (50 or 60 Hz), as can be verified on the voltage label attached to the power cord or as indicated on the plate data label, which is located on the back of the appliance (see the figure of the label in item 2.2 of this manual).

Make sure that the power grid voltage where the appliance will be installed is compatible with the voltage indicated on these labels.

For details of the remainder of the electrical part of the equipment, refer to the electrical schema in the manual annexes.

IMPORTANT

The manufacturer shall not be liable for any direct or indirect damages caused by non-compliance with these standards and other instructions presented in this manual.

3.3 Safety Measures and User Instruction

The professional that makes the sale of the equipment should instruct the user about the correct operation of the equipment and should give you this instruction manual.

The user must be informed of the necessary safety measures and must respect them as well as all the measures described in this manual.

Your appliance has mechanical protections (see item 1.2 Mechanical Safety) that prevent access to moving parts and electrical components. Removal or tampering with these safety components can cause serious risks to the operator's upper limbs.

4. Use of the Appliance

4.1 Utility

The appliance is intended exclusively for crushing various foodstuffs with the addition of liquid.

4.2 Commands

The appliance consists of on/off button and handle (lock).

The on/off button is on the front of the appliance. The handle (lock) is positioned on the right side of the easel.

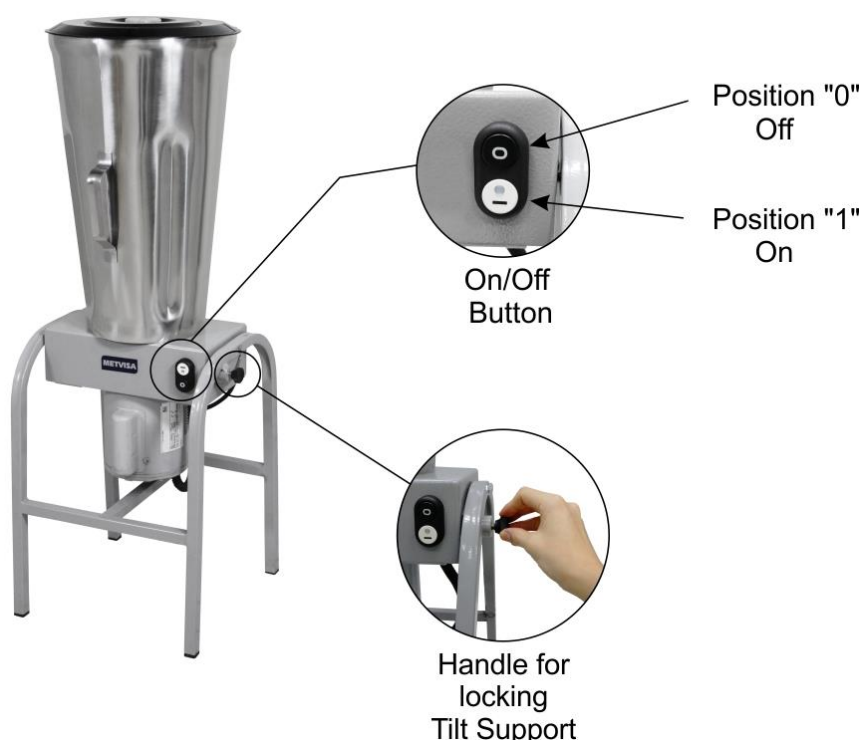

See description of each command below:

- **On/Off Button** - used to turn the appliance on and off. In position "1" it turns the appliance on, and turns it off in position "0".
- **Handle (lock)** - its function is to lock and unlock the cup tilt system. By pulling out the handle, the tilt support will unlock, allowing the cup to tilt. To lock the cup, position the tilt support upright until the handle enters in the lock, preventing cup movement.

4.3 Operating Procedures

Before operating your appliance, make sure that the items that come into contact with the food (cup and lid) are perfectly clean. Clean with the appliance disconnected from the power grid. Follow the cleaning instructions in item 5 of this manual.

Check that the tilt support is locked with the handle (cup in the upright position). Also check that the supply voltage of the appliance complies with that of the electrical network.

After verifying these items, follow the operating procedures of the appliance:

- Connect the power cord to the power grid;
- Add the liquid to the cup according to your recipe, but always observe the "max" level indicated on the internal and external part of the cup. Then add the pre-cut pieces of food;
- Put the lid on the cup;
- Push the on-off button to position "1" (on);
- To add ingredients during processing, remove the lid by turning it counterclockwise and pulling it vertically upwards. Use the opening in the cover without having to remove it;
- Allow time necessary to process food properly;
- After the process is finished, turn the appliance off by pushing the on-off button into position "0" (off).
- To remove processed food, follow the instructions below:
 1. Position a container behind the appliance;
 2. Remove the lid, firmly hold the cup handle and pull the handle (lock) to unlock the cup (as instructed in item 4.2);
 3. Tilt the cup until all liquid is poured into the container;
 4. Return the cup to the upright position until the handle locks the tilt support.



IMPORTANT

It is recommended to remove the lid only for a quick view of the food being processed.

Never turn on the appliance while the cup is open, and do not tilt the cup while the appliance is in operation.



ATTENTION!

If food sticks to the wall of the cup, turn off the appliance and unplug the appliance from the socket. Use a spatula to remove food from the wall of the cup.

In order not to damage the appliance, never switch it on with an empty cup.

Immediately wash the cup after processing acidic foods such as: pepper, vinegar, citrus, sauces, etc. Acidic foods can compromise the cup's sealing system.

If you notice that the appliance cannot process food or that it stops processing, decrease the amount or size of food in the pre-cut before inserting it into the cup.

It is not recommended to crush ice, food with a temperature above 90°C and also solid food without adding any liquid, as this may cause overheating, damaging the cup sealing system, wear of the blades and other components of the appliance.

Failure to comply with these guidelines will be considered an unsafe act and abusive use of the appliance.



ATTENTION!

Never place hands, fingers or objects inside the cup while the appliance is on, as this could cause an accident.

In the case of any irregularities contact your nearest technical assistance center.

5. Cleaning and Maintenance

5.1 Cleaning Procedures and Products Used

Your appliance has been built with first class materials, so use it correctly and you will get great satisfaction. Keep your appliance clean and well cared for at all times, as this will give it a much longer service life.

A daily cleaning of the machine must be carried out for good operation and durability.



ATTENTION!

Before performing maintenance or cleaning, make sure that the on/off switch is in the "0" (off) position and the plug is disconnected from the power grid.



ATTENTION!

Do not use a water jet to clean the appliance.

IMPORTANT

This equipment is not intended to be fully immersed in water for cleaning. Follow the instructions below to find out which parts can be immersed and the special care to be taken with the other parts.

To sanitize the cup, follow the instructions below:

- With the cup in an upright position and the tilt support locked through the handle (lock), add water and a little neutral detergent into the cup, put the lid on and turn on the appliance for a few seconds. Turn off the appliance, remove the liquid as instructed in item 4.3. (pag. 12). Repeat the operation, but only adding water for rinsing.

The removable part (only the lid) must be removed from the appliance and washed with running water and neutral soap. Clean the corners thoroughly, eliminating food residue.

The remainder of the equipment should be cleaned as many times as possible to prevent food residue from drying out and sticking to parts.

Never use abrasive products or sponges for cleaning as they may scratch or ruin the part surface. Do not spill water on the appliance for cleaning, otherwise, turning it on may cause electric shock or even burn the appliance.



ATTENTION!

Take care when cleaning the glass, as the blades are exposed and are extremely sharp. Handle with care, otherwise it could cause accidents. The same attention is paid to any other sharp component of the appliance.

IMPORTANT

The manufacturer shall not be liable for any direct or indirect damages caused by non-compliance with these standards and other instructions presented in this manual.



ATTENTION!

It is extremely important that the products used in cleaning ensure maximum cleanliness and are not toxic.

5.2 Maintenance and Behavior in Case of Breakdowns

The operator must be instructed to perform routine inspections, making minor adjustments, the cleaning and to observe signs of breakdowns that could occur. Examples include: checking for extraneous noise; loss of power of the appliance; the non-performance by the appliance of the service to which it proposes; among others. Actions such as these are essential to ensure a longer equipment life.



ATTENTION!

When maintenance is made (even if small adjustments), always unplug the appliance from the mains.



ATTENTION!

The blades may be re-sharpened when they lose their cut. To do this, contact the nearest technical assistance.

It is recommended to carry out preventive maintenance every 6 months, checking and adjusting clearances, cleaning internal parts, etc.. When detecting broken or malfunctioning parts, always replace using original parts.

By carrying out preventive maintenance, the inconvenience of keeping the appliance still when needed most is eliminated, the cost of maintenance is reduced and the risk of accidents is reduced.



ATTENTION!

Preventive maintenance requires a trained professional.

Make sure the appliance is disconnected from the power grid.

Whenever an item related to the safety of the appliance is removed (e.g. when performing maintenance), put it back in its proper place and confirm that it is performing its function correctly.

When a breakdown or non-compliance is detected, refer your appliance to the nearest technical assistance. See a list of technical assistance on our website: www.metvisa.com.br

5.3 Prolonged Interruption of Appliance Use

When you have to leave the appliance idle for an extended period of time, disconnect it from the power grid and perform a complete cleaning, including the different accessories. It is advisable to protect all parts of the appliance with white vaseline oil or suitable commercially available products. You should also protect the equipment from dust by covering it with a nylon screen or other material.

6. Analysis and Troubleshooting

6.1 Problems, possible causes and solutions

Products with IMG quality are designed with materials and components that guarantee longer life to your equipment. However, due to natural wear, improper use or lack of maintenance, the equipment may have irregularities in its operation.

In the following table, you can check possible causes and solutions:

PROBLEMS	POSSIBLE CAUSES	SOLUTIONS
Appliance doesn't turn on.	- Lack of electricity.	- Check if there is power in the electric grid; - Check connection of the power cord to the electric grid; - Check that the on/off button is in the "1" (on) position.
	- Poor contact in internal electrical connections.	Contact or refer the appliance to Authorized Technical Assistance.
	- Appliance voltage different from power grid voltage.	
	- Problems with the motor.	
The blades stop rotating during operation.	- Lack of electricity.	- Check for bad contact between the power cord and the power grid.
	- Food locked in the blades.	- Turn off the appliance and unplug the power plug. Use a spatula to remove food from the blade.
The appliance turns on but rotates at low rotation when it comes in contact with the food.	- Defect with motor starting capacitor.	Contact or refer the appliance to Authorized Technical Assistance.
	- Problems with the motor.	
	- Ice crushing, as well as solid foods without adding any liquid.	- Do not crush ice. - Decrease the amount or size of the pre-cut food before inserting it into the cup and add liquid.
Smell of burning and/or smoke.	- Appliance voltage different from power grid voltage.	Contact or refer the appliance to Authorized Technical Assistance.
	- Problems with the motor.	
	- Problems in the internal and external electrical circuit of the appliance.	

Strange noises.	- Incorrectly fitted cup in coupling and cup holder.	- Check the coupling and support images in the item Mechanical Safety (p. 5).
	- Badly fixed parts	Contact or refer the appliance to Authorized Technical Assistance.
Damaged electrical cable.	- Transport damage; - Improper use and or disposal of the appliance.	The electrical cable must be exchanged by the manufacturer, authorized agent or qualified person in order to avoid risks.
Difficulty grinding food.	- Blades without cutting.	- Contact or refer the appliance to Authorized Technical Assistance.
	- Ice crushing, as well as solid foods without adding any liquid.	- Do not crush ice. - Decrease the amount or size of the pre-cut food before inserting it into the cup and add liquid.

For more information and clarifications, contact the nearest Authorized Technical Assistance. See a list of technical assistance on our website: www.metvisa.com.br

7. Useful life of the Appliance and its Components

The life of the equipment can vary from 3 to 5 years depending on the proper use, cleaning, maintenance and quality of its components.

The following is the useful life relationship of the major components:

- On / Off button: 10000 maneuvers;
- Cables and electrical wires: 25 years;
- Electrical terminals: 8 years.

8. ANNEXES

Electrical Schema - LQL.19/25 Voltage 110 V or 220 V 60 Hz

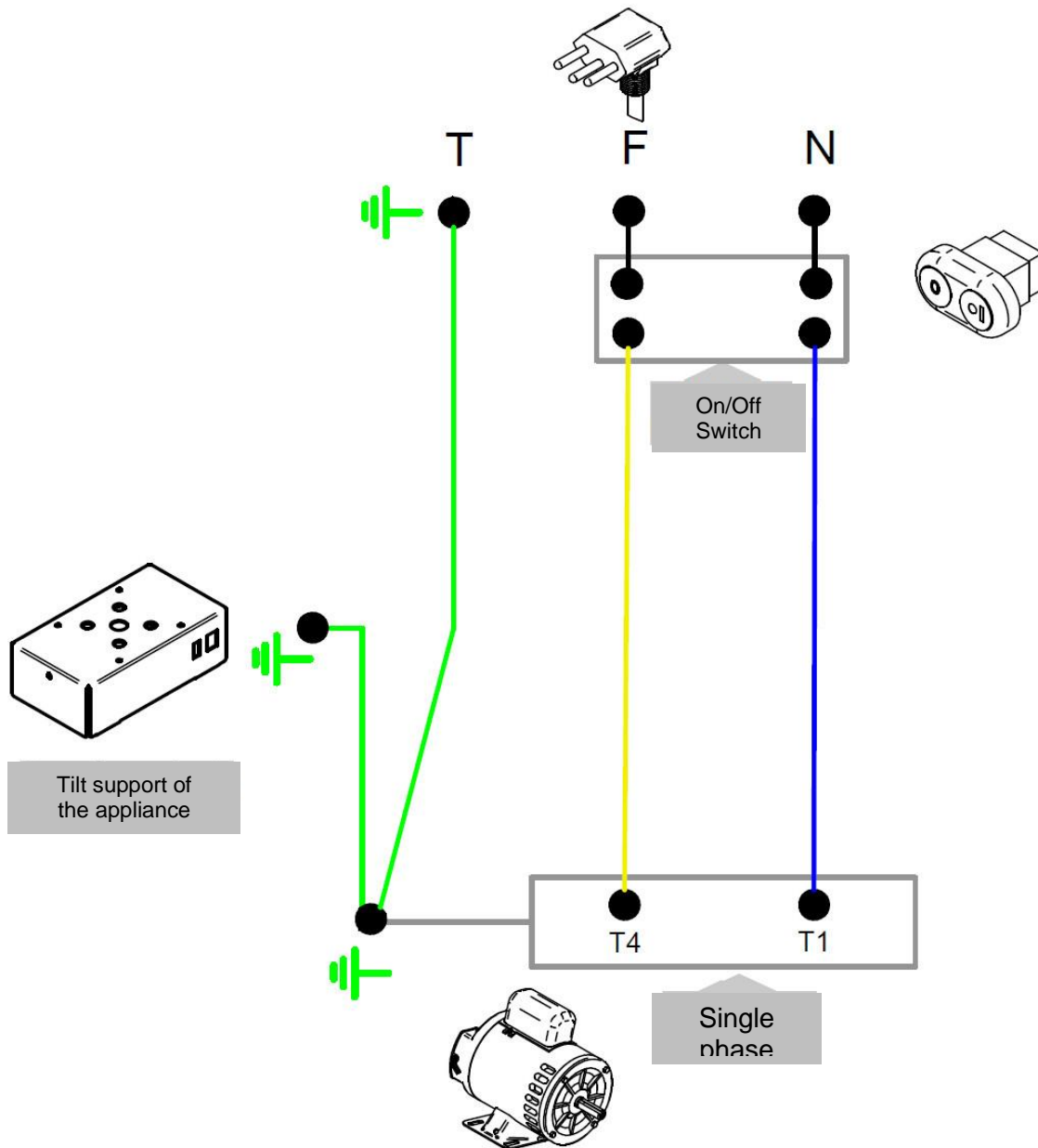

ATTENTION: The ground connection varies according to the type of plug.
For electrical installation observe the current standards of the country, especially with regard to ground connection (if applicable).

Electrical Schema - LQ.19/25 Voltage 220 V 50 Hz

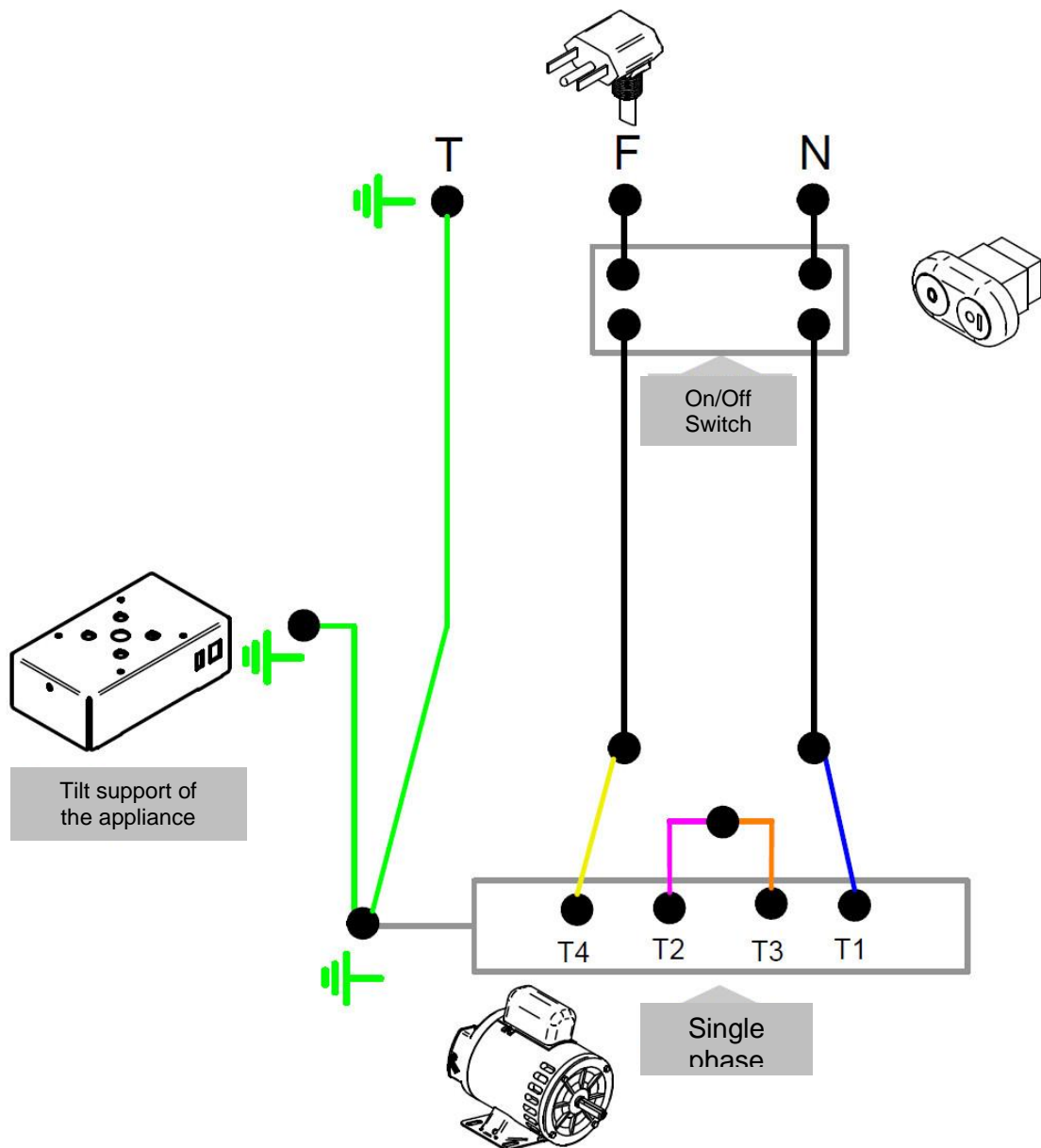

NOTE: In the above electrical schema, white wires are represented by pink.

ATTENTION: The ground connection varies according to the type of plug. For electrical installation observe the current standards of the country, especially with regard to ground connection (if applicable).

Exploded Drawing

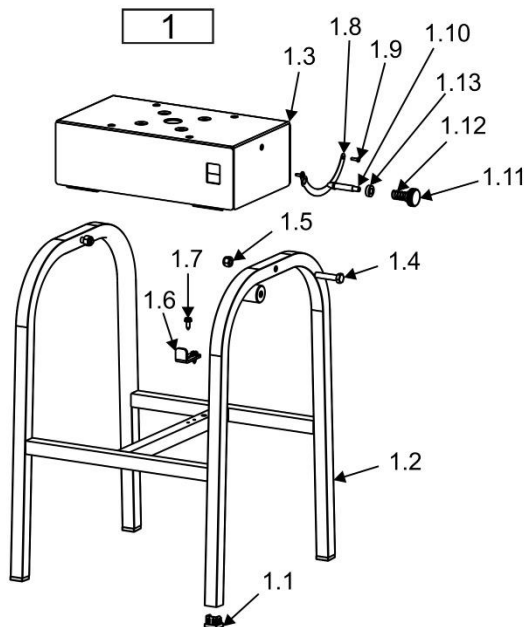
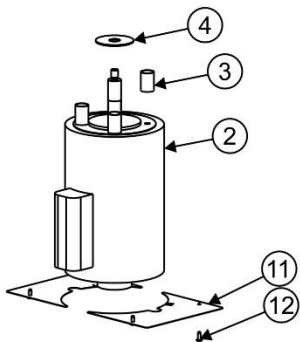
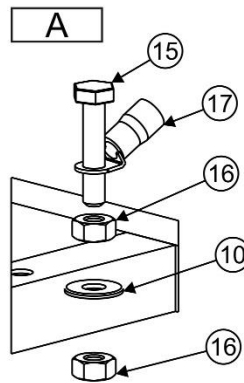
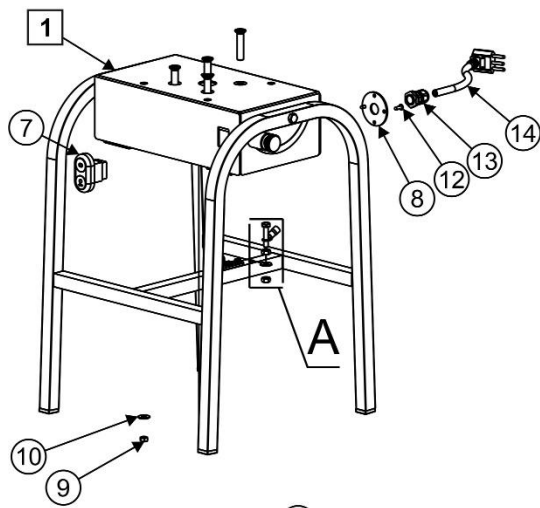
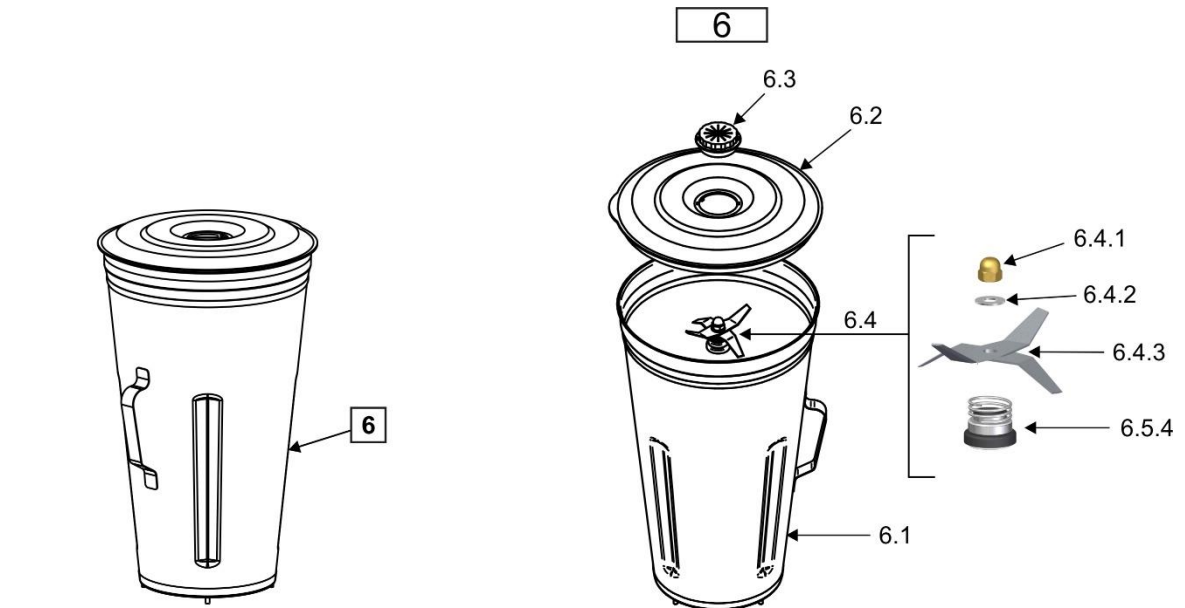

* Image merely illustrative.
Appearances can vary according
to the model.

Cable and plugs are not in the drawing,
please consider in the spare parts list.

Replacement Parts

Item	Code	Description	Quantity	Model
1	CVT018	Complete Easel	1	*
1.1	SPT003	Plastic shoe	4	*
1.2	CVT019	Easel	1	*
1.3	SBT409	Tilt Support	1	*
1.4	PRS009	Zinc Plated Hex Screw	2	*
1.5	POS168	Zinc Plated Self-Locking Hex Nut	2	*
1.6	BTT014	Engine Stopper	1	*
1.7	PRA007	Hex Slotted Tap Screw	2	*
1.8	CRC747	Tipper Guide	1	*
1.9	RBT002	Rivet	2	*
1.10	EIX161	Tilting Axle Lock	1	*
1.11	MNL011	Handle	1	*
1.12	MOL024	Spring	1	*
1.13	BGT040	Tipper Shaft Bushing	1	*
2	MTE227	Electric Motor 1 HP 220 V - 60 Hz	1	LQL.19
	MTE226	Electric Motor 1 HP 110 V - 60 Hz		LQL.19
	MTE073	Electric Motor 1 HP 220 V - 50 Hz		LQL.19
	MTE228	Electric Motor 1,5 HP 110 V - 60 Hz		LQL.25
	MTE229	Electric Motor 1,5 HP 220 V - 60 Hz		LQL.25
	MTE033	Electric Motor 1,5 HP 220 V - 50 Hz		LQL.25
3	SBT055	Motor Elongator	4	*
4	RET008	Disc Scrubber	1	*
5	PRC001	Flat Machine Screw	4	*
6	CJT1264	Full Stainless Steel Cup - LQL.19 Exp.	1	LQL.19
	CJT1268	Full Stainless Steel Cup - LQL.25 Exp.		LQL.25
6.1	COP183	Stainless cup - LQL.19	1	LQL.19
	COP186	Stainless cup - LQL.25	1	LQL.25
6.2	TAP189	Plastic Lid	1	*
6.3	TAP103	Overcap of the Blenders	1	*
6.4	CJT132	Blade Seal Set	1	*
6.4.1	POC014	Top Nut	1	*
6.4.2	ARL012	Flat Washer	1	*
6.4.3	LMT001	Stainless Blades	1	*
6.4.4	SLM001	Mechanical Seal	1	*
7	CHE064	On/Off Button	1	*
8	SBT439	Stainless Large Cable Gland Support (TCE041)	1	**
	SBT513	Stainless Small Cable Gland Support (TCE073)		**
9	POS018	Hexagonal Nut	4	*
10	ARL004	Flat Washer	5	*
11	PTC073	Tilt Support Protection	2	*
12	RBT004	Rivet	6	*
13	TCE073	Small Cable Gland (SBT513)	1	LQL.19 (220 V)
	TCE041	Large Cable Gland (SBT439)		LQL.19 (110 V) / LQL.25
14	CBE003	Electric Cable - Type 4	1	**
	CBE001	Electric Cable - Type 4		**
	CBE002	Electric Cable - Type 4		**
	CBE010	Electric Cable - Type 3		**
	CBE011	Electric Cable - Type 3		**
	CBE007	Electric Cable - Type 2		**
	CBE008	Electric Cable - Type 2		**
	CBE021	Electric Cable - Type 1		**
	CBE020	Electric Cable - Type1		**
15	PRS037	Hexagonal Screw	1	*
16	POS005	Hexagonal Nut	2	*
17	TCE023	Equipotential Grounding Terminal	1	*
18	-	Electrical Cables and Connectors below:	-	-
18.1	TCE033	Orange Threaded Connector	2	*
18.2	TCE013	Female Terminal	5	*
18.3	BCH072	Hose	1	*
18.4	CBE199	Electrical Seam Cable	1	*

* Item applicable for all models of tilting blenders.

** For electrical cable codes and cable gland support, refer to item 2.2 (Technical Data) in this manual, authorized technical assistance or factory.

IMG BRASIL PRODUCT MANUFACTURER



IMG-BRASIL Gastronomy Machinery Industry Ltda.

CNPJ 11.193.347/0001-14 - CREA 131726-3

Rod. Antônio Heil – KM 23 Nº 5825 – Limoeiro

CEP 88352-502 - Brusque – SC – Brazil

Phone/fax. +55 47 3251-5555 - Site: www.metvisa.com.br

E-mail: sac@metvisa.com.br - export@metvisa.com.br - export2@metvisa.com.br



Discover our complete
line of products.