



INSTRUCTION MANUAL

Installation | Maintenance | Use | Safety

Electric Frying Bowl

Model

TFE.6



Image merely illustrates.

CONGRATULATIONS,

You have just purchased a IMG-BRASIL equipment, product of the highest quality, safety and efficiency.

Founded in 1989, IMG-BRASIL is a respected company as one of the best and most complete companies in the field of gastronomy equipment manufacturing.

Constant innovation and improvement of its products, using top-of-the-line raw materials, ensure superior products consumed in Brazil and in more than 25 countries worldwide.

THE RELIABILITY AND CERTAINTY OF A GOOD PRODUCT ARE IN THE NAME

IMG BRASIL PRODUCT MANUFACTURER



IMPORTANT:

**PRODUCT FOR PROFESSIONAL USE. DO NOT USE BEFORE READING
THE MANUAL CAREFULLY.**

IN CASE OF QUESTIONS, PLEASE CONTACT US:

IMG-BRASIL Indústria de Máquinas para Gastronomia Ltda

CNPJ 11.193.347/0001-14 - CREA 131726-3

Rod. Antônio Heil - KM 23 Nº 5825 - Limoeiro - Brusque - SC - Brazil

Phone/fax.47 3251-5555 - Website: www.metvisa.com.br

E-mail: sac@metvisa.com.br - vendas@metvisa.com.br

TABLE OF CONTENTS

1. Safety Information	4
1.1 General Warnings	4
1.2 Mechanical Safety	5
1.3 Electrical Safety	5
2. Technical Features	6
2.1 Main Components	6
2.2 Technical Data	7
2.3 Supply and Disposal of Device Packaging	8
3. Installation	8
3.1 Equipment Layout	8
3.2. Electrical Connection	9
3.3 Safety Measures and User Instruction	10
4. Use of the Device	11
4.1 Utility	11
4.2 Commands	11
4.3 Operation Procedure	12
5. Cleaning and Maintenance	14
5.1 Cleaning Procedures and Products Used	14
5.2 Maintenance and Behavior in Case of Breakdowns	15
5.3 Prolonged Interruption of Device Use	16
6. Analysis and Troubleshooting	16
6.1 Problems, possible causes and solutions	16
7. Useful life of the Device and its Components	17
8. ANNEXES	18
Electrical Schema	18
Exploded Design	19
Replacement parts	20
Term of Guarantee	21



ATTENTION!

The characteristics, pictures and figures presented in this manual should be considered for information purposes. IMG BRASIL reserves the right to make such modifications as may be deemed necessary without prior notice.

1. Safety Information

1.1 General Warnings

- There are precautions that must be observed when assembling, using, maintaining and discontinuing the use of this device;
- Before performing any operation (assembly, use (use), maintenance and re-use after prolonged interruption of use of the appliance), read this manual carefully;
- The device must be used by people trained and knowledgeable in use and safety requirements described in this manual;

This device is not intended for use by persons (including children) with reduced physical, sensory or mental capacities, or people with lack of experience and knowledge, unless they have received instructions regarding the use of the device or are under the supervision of a person responsible for their safety;

- It is recommended that children be supervised to ensure that they are not playing with the equipment;
- In case of alternation of staff to work with the device, the new operator must be instructed on the rules and the operation of the device;
- Operator should wear appropriate Personal Protective Equipment (PPE), such as for example: use kevlar sleeves or non-flammable fabric to avoid oil burns; wear anti-slip shoes; among others;
- The operator should always be aware of situations that may cause and avoid accident hazards (such as, for example, working on dirty floors where someone may slip and fall on the appliance);
- After reading and answering all questions, this manual should be carefully stored in an easily accessible place, known by all the people who will operate the device and made available to the people who will carry out maintenance, for eventual consultations. When in doubt, consult the manual. Do not operate the device in any way with doubts;
- In the installation, it is essential to make this manual available to the professionals who will do the same;
- Never splash water on hot oil as this may cause major accidents. In case of accident, use non-flammable material to extinguish the focus. You can even place a tray or metal lid over the saucepan to muffle the focus;
- Before starting cleaning and any kind of maintenance, it is essential to disconnect the appliance from the power supply and wait for the oil to completely cool down;
- Periodically check the condition of the cables and electrical parts.



ATTENTION!

Do not perform repairs on your own. Refer to the technical service authorized by the manufacturer. Use only original parts in your device.

1.2 Mechanical Safety

- Since the appliance is designed and produced for professional use, considering its purpose/usefulness, the handling of some components (for example: frying baskets) must be carried out with care;
- Before turning on the appliance, make sure that the bulbs of the temperature and safety thermostats are in perfect condition, i.e. they must not be squashed or have any other malfunction. Faulty thermostats impair the correct functioning of the device and temperature reading, which may cause accidents;
- Never splash water on the oil as this may cause a serious accident;
- If you need to move some frying, use a spatula;
- Your appliance has a basket for disposal of fried foods;
- Avoid splashing oil on the floor as this will make the floor slippery and may cause accidents. In case of oil splashes, clean the floor.

The equipment described in this manual complies with the mechanical risk regulation.

Mechanical safety is achieved with:

- **Cabinet**, which protects the entire saucepan (which is heated to high temperatures). This prevents burns to the operator;
- **The frying basket** facilitates the handling of the fried foods;
- **Electric box**, which prevents operator access to electrical parts and protects all electrical components, avoiding contact with water, dust and other materials;
- **Resistance protection** prevents frying basket contact with the fryer resistance, avoiding the risk of burns and damage to the fryer resistance.

To view the parts described above, refer to the image in item 2.1 (Main Components - pg. 7) of this manual.



ATTENTION!

Whenever any item regarding the safety of the equipment (such as cleaning or maintenance) is removed, reset it and confirm that it is performing its function correctly.

1.3 Electrical Safety

- Periodically check the condition of the cables and electrical parts;
- Never splash water on your device. If the oil is hot, it could cause a serious accident and still drip onto the electrical connectors and cause electric shock;
- If the power cord is damaged, it must be replaced with a new one. The exchange must be made by the manufacturer, authorized agent or a qualified person in order to avoid risk;

- Do not operate the equipment in damp locations or wet clothing and shoes. Wear proper footwear, this will prevent electric shocks and even death;
- Support the appliance on a firm and dry surface;
- Never carry out any maintenance, adjustment or disassembly of the equipment connected to it. For such procedures, make sure that it is turned off by removing the plug from the electrical outlet;
- To adjust the operating temperature of the device, there is a button on the temperature thermostat. This button should be used to adjust the temperature according to the needs of the product to be fried, avoiding overheating of the oil. When the set temperature is reached, the thermostat will turn off the fryer resistance and automatically turn off the signal lamp;
- The appliance also has a safety thermostat*, which turns the appliance off in case the temperature thermostat fails.

IMPORTANTE

*** If the item does not apply to your equipment, please disregard.**

See the information and location of the components mentioned above in item 4.2 (Commands).

The components used for safety against electrical hazards were selected according to applicable regulatory standard. Given the perfect insulation of all the electrical parts and the excellent resistance of all the materials used, this unit is able to carry out the works to which they are proposed.



ATTENTION!

Whenever an item related to the safety of the appliance is removed (for example, when cleaning or maintaining it), put it back in its proper place and confirm that it is performing its function correctly.

2. Technical Features

2.1 Main Components

For the equipment described in this manual, safety in use, cleaning, maintenance and maximum hygiene are guaranteed by the design and special project for all parts, as well as by using stainless steel and other materials suitable for contact with food.

The device was built with the following features:

- Cabinet and electrical box manufactured stainless steel, which has superior corrosion resistance to other steels. It's a material resistant to the attack of several corrosive agents;
- Saucepan and fryer resistance protection, made of aluminum. It is a lightweight material, durable and resistant to attack by corrosive agents.

The following are the main components of the equipment:

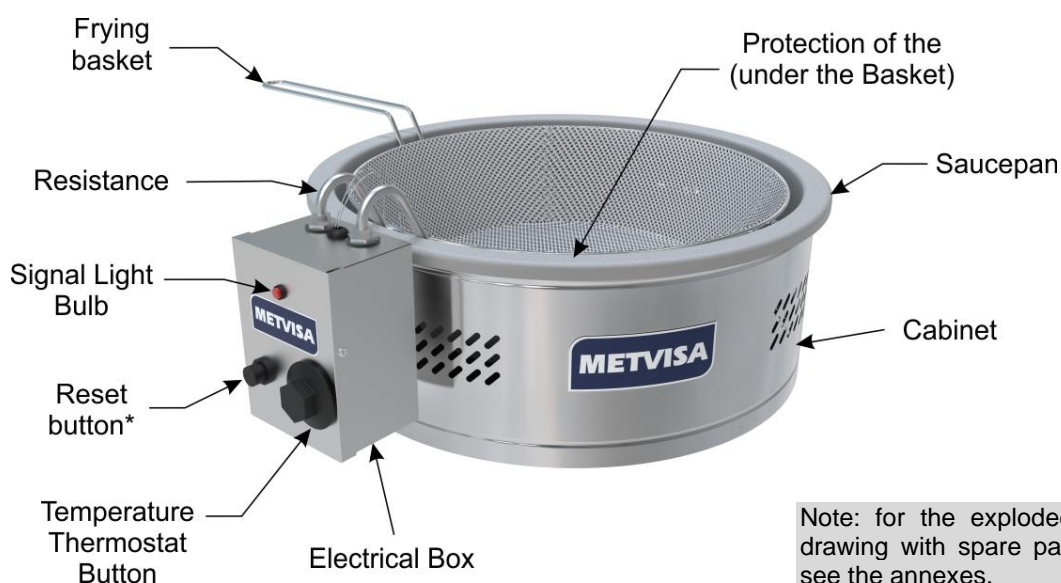

Note: for the exploded view drawing with spare parts list, see the annexes.

IMPORTANTE

* If the item does not apply to your equipment, please disregard.

2.2 Technical Data

Model	Nominal Use Measures LengthxHt.xDepth	Net weight (kg)	Voltage (V)	Rated current (A)	Capacity (L)
TFE61275	775x220x460	4.0	127	24	6
TFE62205	775x220x460	4.0	220	16	6
TFE61104	775x220x460	4.0	110	24	6
TFE62201	775x220x460	4.0	220	16	6
TFE62202	775x220x460	4.0	220	16	6
TFE62204	775x220x460	4.0	220	16	6
TFE62207	775x220x460	4.0	220	16	6

Note: The appliance power supply requires a 25 A to 127 V or 110 V and 16 A to 220 V circuit breaker



ATTENTION!

Characteristics such as: model, serial number and voltage of the device are provided on the data label (figure below). Before installation, check that the power supply voltage of the device corresponds to that of the power grid.



2.3 Supply and Disposal of Device Packaging

The equipment is packed with wood or cardboard to ensure its perfect integrity during transport and is accompanied by the following documents:

- Instruction Manual for Installation, Use, Maintenance and Safety;
- Warranty Term (for Brazilian market).

IMPORTANT

The packaging components (cardboard, wood, foam, foil, etc.) are products assimilable to urban solid waste and can be disposed off without difficulty. In the event that the device is installed in countries where there are different standards, eliminate the packaging in accordance with current standards. Perform the correct disposal of the product helping to protect the environment. For more information about recycling the same, contact the local authorities, the garbage collect service or the shop where you purchased the product.

3. Installation

3.1 Equipment Layout

The connection to the mains and the arrangement for operation must be carried out by a qualified professional. Check that the voltage of the equipment matches the mains voltage.

It is essential to make this manual available to the professionals who will carry out the installation.

To ensure correct operation and safety, the device must be positioned in a ventilated environment and on a sufficiently wide, level, dry and stable support surface, away from sources of heat and water faucets, and at an average height of 80 cm. Install your appliance by leaving a distance of at least 30 cm around it so that it has sufficient space for inspection, maintenance, cleaning and use.

It is recommended that the place/establishment where this appliance is installed/used be equipped with an appropriate fire extinguisher in accordance with local regulations and requirements. The use of carbon dioxide extinguishers (also known as CO2 carbon dioxide extinguishers), is recommended. Do not use chemical powder or water extinguishers, as these will only increase the fire. Note: In case of fire, you can even place a metal tray or lid on the saucepan to muffle the focus.

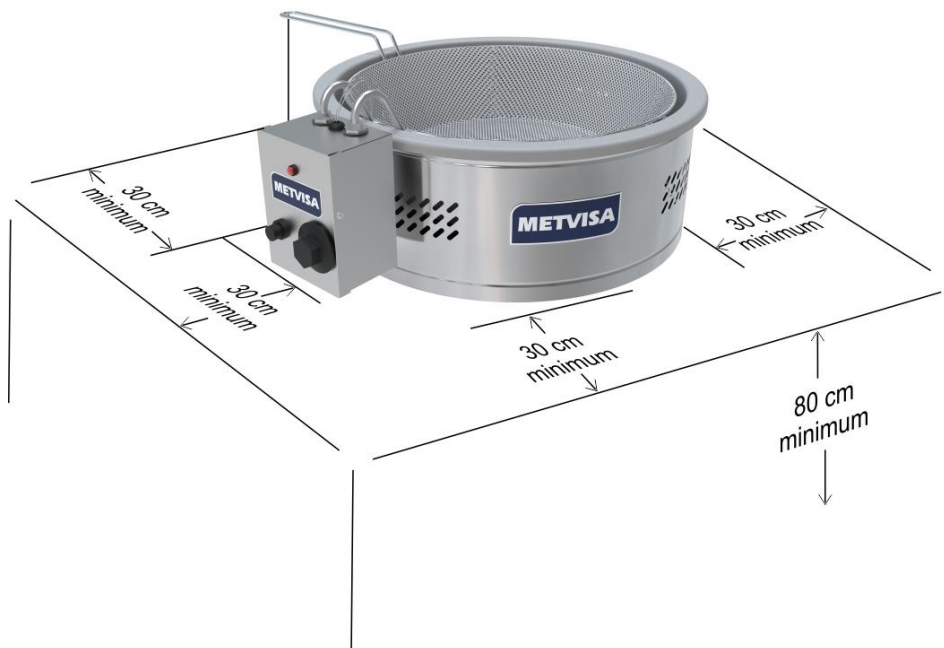

ATTENTION!

The installation and the place where the device will be disposed of must be in accordance with the norms of risk prevention and safety at work (Regulatory Norm NR-12 for Brazil or according to the regulatory norm in force in your country).

The manufacturer shall not be liable for any direct or indirect damages caused by non-compliance with these standards and other instructions presented in this manual.

3.2. Electrical Connection

The equipment comes with a power cord to be plugged into an electrical outlet. If the power cord is damaged, it must be replaced with a new one. The exchange must be made by the manufacturer, authorized agent or a qualified person in order to avoid risk.

The power cord plug has 3 round pins, and there is a corresponding marking of each one (Phase, Ground and Neutral) just below each pin. It is mandatory to make a good ground connection according to the current regulations.

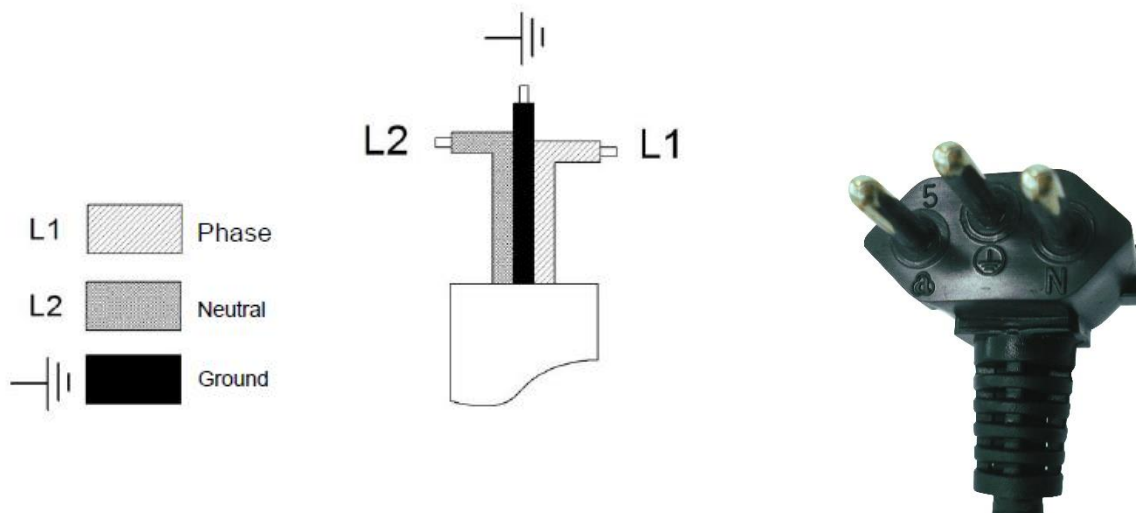

All models of the devices described in this manual are single-phase and have a single voltage, i.e. 127 V or 220 V. If it is necessary to change the voltage in your device, contact the manufacturer or the authorized dealer.



ATTENTION!

Before connecting your appliance, always check that the supply voltage of the network is the same as the voltage of the equipment.

The supply voltage of this device is 110 V, 127 V (60 Hz) or 220 V (50 or 60 Hz), as can be checked on the voltage label attached to the supply cable or as indicated on the plate data label on the back of the device (see the figure of this label in section 2.2 of this manual).

Make sure that the power grid voltage where the appliance will be installed is compatible with the voltage indicated on these labels.



ATTENTION!

The power supply of the appliance with voltage 127 V or 110 V requires a 25 A circuit breaker and for 220 V a 16 A circuit breaker. The conductor must be 4 mm² section.

For details of the rest of the electrical part of the appliance, refer to the electrical schema in the annexes of the manual.

IMPORTANT

The manufacturer is not responsible for possible direct or indirect damages caused by non-compliance with rules and instructions in this manual.

3.3 Safety Measures and User Instruction

The professional that makes the sale of the equipment should instruct the user about the correct operation of the equipment and should give you this instruction manual.

The user must be informed of the necessary safety measures and must respect them as well as all the measures described in this manual.

Your device has mechanical protections (see item 1.2 Mechanical Safety) that prevent access to moving parts and electrical components. Removal or tampering with these safety components can cause serious risks to the operator's upper limbs

4. Use of the Device

4.1 Utility

This appliance can be used to fry various food products using oil.

4.2 Commands

Positioned in front of the electrical box, the thermostat temperature control button, the signal lamp and the reset button (safety thermostat)* are visible.

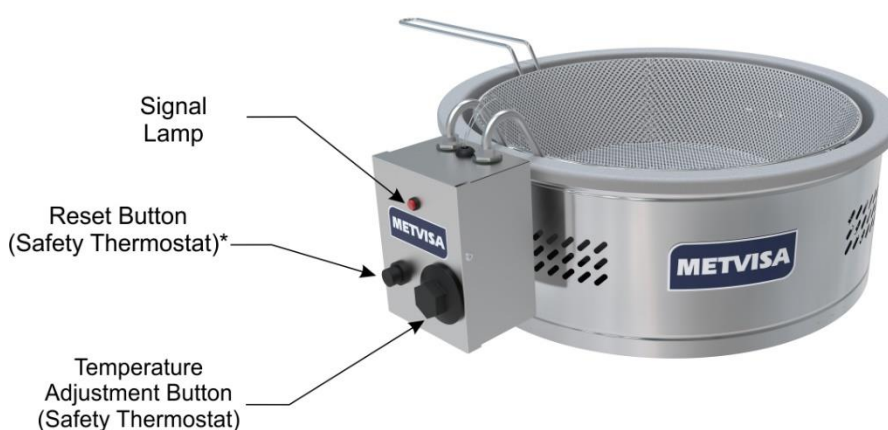

See the figure above and the description of each command:

- **Temperature Adjustment Button:** used to set the desired temperature according to the product to be fried.
- **Signal Lamp:** has the function of indicating when the desired temperature is reached. When the selected temperature is reached, the lamp will turn off automatically, turning off the resistance.
- **Reset Button*:** is a component of the safety thermostat. It is used to reset the device, when the temperature thermostat shows any fault and/or defect.

IMPORTANTE

* If the item does not apply to your equipment, please disregard.



ATTENTION!

When a temperature thermostat is defective, immediately have your appliance inspected by an authorized service center for replacement.

4.3 Operation Procedure

Before operating the appliance, carry out a perfect cleaning, especially of the components that will come into contact with food. Clean with the appliance disconnected from the power supply. Follow the cleaning instructions in item 5 of this manual.

After these initial precautions, confirm that the supply voltage of the power grid is the same as that of the appliance and that the bulbs of the temperature and safety thermostats* are in perfect condition, i.e. they must not be scrunched or have any other malfunction. Faulty thermostats impair the correct operation of the device and the temperature reading and may cause accidents.

IMPORTANTE

*** If the item does not apply to your equipment, please disregard.**



ATTENTION!

Never start your appliance on an empty saucepan as this will cause the fryer resistance to burn out and damage the entire structure.

The appliance may only be operated after checking that the voltage of the appliance is in accordance with the electric power supply network.

• Operation:

1. Add oil to the saucepan covering the fryer resistance. Note: Recommended oil type: sunflower, soy or corn. Hydrogenated or vegetable fat and cottonseed oil is not suitable for this appliance.

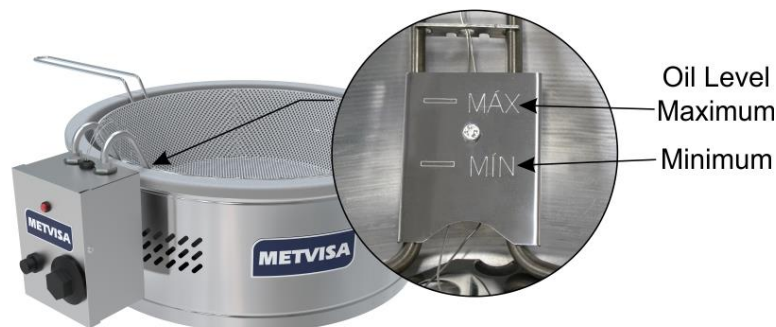

ATTENTION!

Do not exceed the maximum capacity of the saucepan, which is 6 liters. Above this there is a risk of overflowing when placing the basket with the food for frying in the saucepan.

There is a danger of fire if the fryer resistance is not submerged in oil.

Always keep the oil level above the fryer resistance, as this prevents accidents and eliminates the risk of burning the resistance.

2. Plug the power cord into the power grid;
3. Set the thermostat to the desired temperature range (it varies according to the product to be fried). Note: when the selected temperature is reached by the thermostat, the signal lamp will turn off automatically turning off the appliance;

4. Add the food to be fried to the basket and bring it to the oil heated to the desired temperature;



ATTENTION!

Add the products to be fried slowly and gradually in the basket, thus avoiding the bubbling and spilling of oil from the saucepan. The bubbling will be intense when frozen products are poured.

Attention should be paid to the effect of increasing boiling in the wet foods and for very large loads.

Never splash water on hot oil as this may cause a serious accident.

Use appropriate PPE and whenever the floor is dirty, clean it.

In an emergency, remove the plug from the electrical outlet.

5. Allow enough time for the product to fry completely (until colored). After that, remove the basket and place in a container to let excess oil drip.

After work has been completed, always clean the appliance (see instructions in item 5 of the manual), replace the appliance components in their proper place. After these procedures, the device will be available again to restart the operation process.

IMPORTANT

It is recommended not to use the same oil for many operating cycles. The use of old oil is dangerous, as it can have a reduced flash point and can be more conducive to boiling surges.



ATTENTION!

Do not empty the saucepan with the oil still hot, wait for the total cooling.

According to instructions from ANVISA (National Health Surveillance Agency) some care should be taken with the oil used in frying. Here are some of them:

- *“The oil must be filtered at each end of use. During the frying of food, especially the breaded ones, which tend to release particles from its surface, remove visible residues in the oil with the aid of an appropriate utensil.”*
- *“The oil should be discarded when there is foaming and smoke during frying, intense darkening of the oil and food coloration and perception of uncharacteristic odor and taste. Remember that the smoke aspect is different from the naturally released vapor”.*

- *“The oil should not be disposed of in the public sewage system, housewives can put it in plastic bags or containers and add it to organic waste. For traders and fast foods, because they discard a significant amount, it is suggested to contact companies, agencies or entities licensed by the competent environmental agency.”*

(Source: ANVISA - Technical Report No. 11, October 5, 2004; Subject: Oils and Fats Used in Frying).

5. Cleaning and Maintenance

5.1 Cleaning Procedures and Products Used

Your device has been built with first class materials, so use it correctly and you will get great satisfaction. Keep your device clean and well cared for at all times, as this will give it a much longer service life.

Change oil whenever necessary. Check the instructions, warnings, and recommendations given in item 4.3 of this manual regarding the care of the oil used.

The appliance should be cleaned daily to ensure proper operation and long service life.



ATTENTION!

Before cleaning the appliance, make sure that the plug is disconnected from the power grid. In addition, wait for the full cooling of the device.



ATTENTION!

Do not use a water jet to clean the appliance.

IMPORTANT

This equipment is not intended to be fully immersed in water for cleaning.

Follow the instructions below to find out which parts can be immersed and the special care to be taken with the other parts.

Demountable parts (saucepan, basket and resistance guard) should be removed from the appliance and washed with warm water and mild detergent. Clean the corners thoroughly, eliminating food residue.

The remainder of the appliance should be cleaned as many times as possible to prevent food residue from drying out and sticking to parts. For cleaning, dilute the soap or neutral detergent in warm water and apply with a soft cloth. With a cloth dampened with water, rinse and then dry the parts with a dry, soft cloth.

Never use abrasive products or sponges and substances containing acids or chlorine to clean the metallic parts, as they may scratch or damage the surface of the parts causing corrosion points. Do not spill water on the engine and electrical parts for cleaning, otherwise, turning it on may cause electric shock or even burn the device.

IMPORTANT

The manufacturer is not responsible for possible direct or indirect damages caused by non-compliance with rules and instructions in this manual.



ATTENTION!

It is extremely important that the products used in cleaning ensure maximum cleanliness and are not toxic.

5.2 Maintenance and Behavior in Case of Breakdowns

The operator must be instructed to perform routine inspections, making minor adjustments, the cleaning and to observe signs of breakdowns that could occur. Examples include: checking for extraneous noise; loss of power of the appliance; the non-performance by the appliance of the service to which it proposes; among others. Actions such as these are essential to ensure a longer equipment life.



ATTENTION!

When maintenance is done (even if small adjustments), always unplug the appliance from the power grid.

It is also recommended to always perform preventive maintenance, checking and adjusting gaps, cleaning the internal parts, etc. When detecting broken or malfunctioning parts, always replace using original parts.

By carrying out preventive maintenance, the inconvenience of keeping the device still when needed most is eliminated, the cost of maintenance is reduced and the risk of accidents is reduced.



ATTENTION!

Preventive maintenance requires a trained professional.

Make sure the device is disconnected from the power grid.

Whenever an item related to the safety of the device is removed (e.g. when performing maintenance), put it back in its proper place and confirm that it is performing its function correctly.

When a breakdown or non-compliance is detected, refer your device to the nearest technical assistance. See technical assistance on our website: www.metvisa.com.br

5.3 Prolonged Interruption of Device Use

When you have to leave the appliance idle for an extended period of time, disconnect it from the power grid and perform a complete cleaning, including the different accessories. It is advisable to protect all parts of the appliance with white vaseline oil or suitable commercially available products. You should also protect the equipment from dust by covering it with a nylon screen or other material.

6. Analysis and Troubleshooting

6.1 Problems, possible causes and solutions

Products with IMG quality are designed with materials and components that guarantee longer life to your equipment. However, due to natural wear, improper use or lack of maintenance, the equipment may have irregularities in its operation.

In the following table, you can check possible causes and solutions:

PROBLEMS	POSSIBLE CAUSES	SOLUTIONS
Device doesn't turn on.	Lack of electricity.	Check for power on the network.
		Check that the power cord is plugged into a wall outlet.
	Device voltage different from network voltage.	Send the equipment to the nearest authorized service station or contact the factory.
	Miscellaneous electrical problems (fryer resistance, thermostats, wiring, reset button, bulbs).	Send the equipment to the nearest authorized service station or contact the factory.
Appliance switches off in the middle of operation.	Lack of electricity.	Check for power on the network.
		Check that the power cord is plugged into a wall outlet.
	Miscellaneous electrical problems (fryer resistance, thermostats, wiring, reset button, bulbs).	Send the equipment to the nearest authorized service station or contact the factory.
Device with the smell of burning or smoke.	Machine voltage different from power grid voltage.	Send the equipment to the nearest authorized service station or contact the factory.
	Miscellaneous electrical problems (fryer resistance, thermostats, wiring, reset button, bulbs).	Send the equipment to the nearest authorized service station or contact the factory.
	The oil has lost the ideal characteristics for frying.	It is recommended not to use the same oil for many operating cycles. Check some ANVISA (National Health Surveillance Agency) instructions on page. 13.

Appliance takes time to fry the food.	Miscellaneous electrical problems (Fryer resistance, thermostats, wiring, reset button, bulbs).	Send the equipment to the nearest authorized service station or contact the factory.
---------------------------------------	--	--

For more information and clarifications, pcontact the nearest Authorized Technical Assistance. See technical assistance on our website: www.metvisa.com.br

7. Useful life of the Device and its Components

The life of the equipment can vary from 3 to 5 years depending on the proper use, cleaning, maintenance and quality of its components.

The following is the useful life relationship of the major components:

- Fryer resistance: 100,000 cycles;
- Temperature Thermostat: 100,000 cycles;
- Cables and wires: 25 years;
- Electrical terminals: 8 years.

8. ANNEXES

Electrical Schema

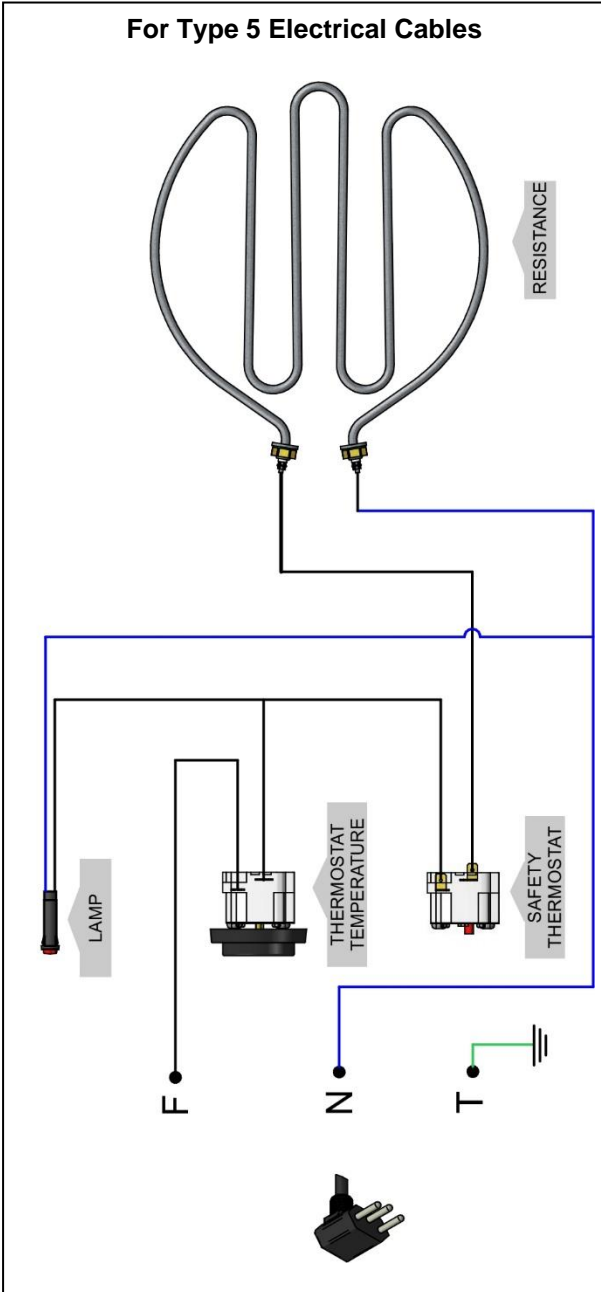
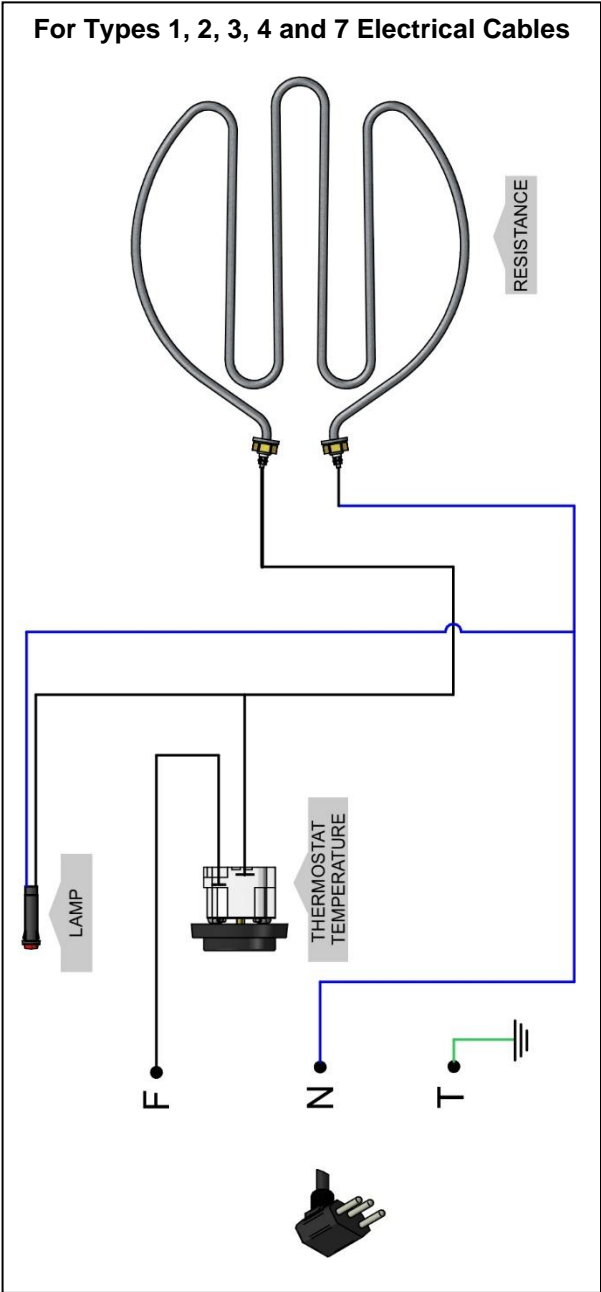

Color key for power cable wiring:

- F = Black
- N = Blue or White (varies by supplier)
- T = Green

Exploded Design

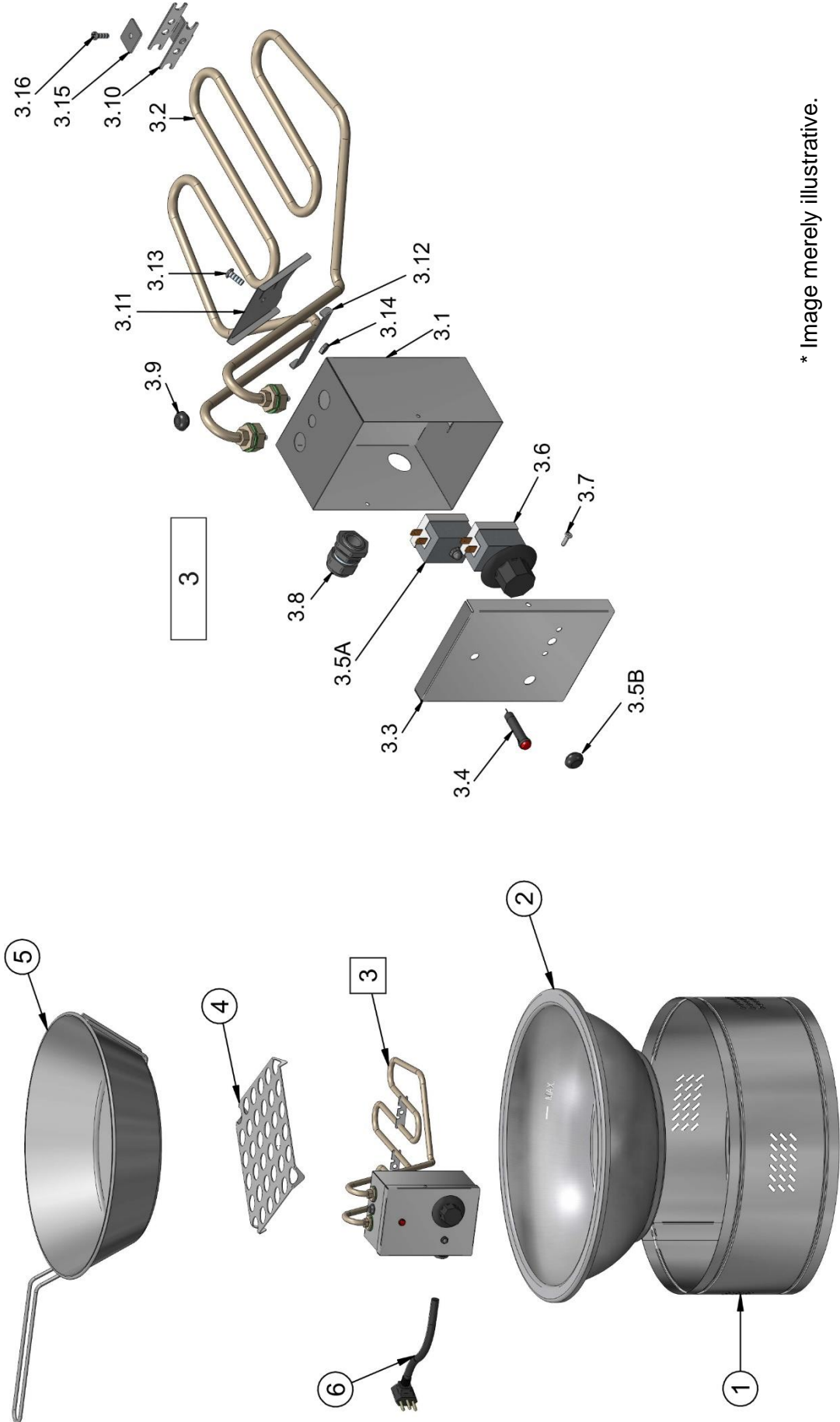

* Image merely illustrative.

Cable and plugs are not in the drawing, please consider in the spare parts list.

Replacement parts

Position	Code	Description	Qty.	Model
1	GAB022	Stainless Cabinet	1	*
2	THO001	Frying Saucepan	1	*
3	CJT929	Complete Electrical Box - 220 V (National)	1	#
	CJT928	Complete Electrical Box - 127 V(National)		#
	CJT1276	Complete Electrical Box - 110 V (Export)		##
	CJT1359	Complete Electrical Box - 220 V (Export)		##
3.1	CXE001	Welded Electrical Box	1	*
3.2	RTE002	Resistance 3500 W - Voltage 220 V	1	*
	RTE003	Resistance 3000 W - Voltage 110/127 V		*
3.3	TAP168	Electric Box Cover	1	*
3.4	LPS004	Lamp	1	*
3.5A	TMT018	Safety Thermostat 30 A - 127 V (National)	1	#
	TMT020	Safety Thermostat 20 A - 220 V (National)		#
3.5B	BCH039	Black Cap (Export)	1	##
3.6	TMT017	Thermostat Set - Voltage 110/127 V	1	*
	TMT019	Thermostat Set - Voltage 220 V		*
3.7	RBT002	Rivet	2	*
3.8	TCE041	Print Cable	1	*
3.9	BCH039	Black Cap	1	*
3.10	SBT652	Bulb Fixing Bracket	1	*
3.11	CRC948	Level Marking	1	*
3.12	CRC949	Level Marking Lock	1	*
3.13	PRR022	Screw	1	*
3.14	POS020	Hex Nut	1	*
3.15	TRV042	Bulb Lock Plate	1	*
3.16	PCC015	Stainless Steel Cylindrical Machine Screw	1	*
4	CUP003	Fryer Resistance Protection	1	*
5	CET003	Small Basket	1	*
6	CBE181	Electric Cable - Type 7	1	**
	CBE145	Electric Cable - Type 5		
	CBE003	Electric Cable - Type 4		
	CBE012	Electric Cable - Type 3		
	CBE009	Electric Cable - Type 2		
	CBE022	Electric Cable - Type 1		
7.1	CBE101	Electric Cable Splice	1	*
7.2	CBE112	Electric Cable Splice	1	*
7.3	TMP005	Black Insulating Heat Shrink Tubing	0,05m	*

* Item applicable to all models of Frying Saucepan described in this manual.

** Consult the nearest technical assistance or the factory.

Item applicable to models with type 5 electrical cables. If in doubt, consult the nearest technical support or contact the factory.

Item applicable to models with type 1, 2, 3, 4 and 7 electrical cables. If in doubt, consult the nearest technical support or contact the factory.

TERM OF GUARANTEE

(for Brazilian Market)



IMG BRASIL, manufacturer of METVISA products, undertakes to guarantee its products against possible manufacturing defects for 180 days (including 90 days of legal guarantee), counted from the date of issuance of the corresponding Sales invoice.

In the cases of the items mentioned above, the warranty is restricted to legal (90 days) only for the items listed below that are considered natural wear or that involve the electrical part:

- Fryer resistance;
- Thermostat.

All components that prove to be defective in their manufacture will be repaired or replaced, as the case may be, free of charge by IMG BRASIL, or any IMG BRASIL AUTHORIZED TECHNICAL ASSISTANCE, within the warranty period and with the presentation of the current WARRANTY TERM duly completed and the corresponding invoice.

This TERM OF WARRANTY does not cover damage or defects caused by:

- Usage of the equipment;
- Lack of conservation and maintenance;
- Improper storage;
- Defects in the electrical network;
- Improper installation;
- Natural wear and tear;
- Transport or inclement weather;
- Lack of use for an extended period;
- Non-compliance with technical information and guidelines.

The alteration of the product or replacement by improper, non-original components, as well as the expiration of the warranty period, render this WARRANTY TERM unenforceable.

IMG BRASIL reserves the right to modify the equipment and its components without previous notice, without having to do the same in equipment already sold.

DATA FOR DATA FOR PROOF OF WARRANTY

PRODUCT

Code: _____

Date of Manufacture: ____ / ____ / ____

Number: _____

PRODUCT INVOICE

Date: ____ / ____ / ____

Number: _____

CONSUMER

Stamp / Signature of Seller

Name: _____

Address: _____

DEALER

Name: _____

Address: _____

Stamp/Signature of Seller

TECHNICAL ASSISTANCE - at@metvisa.com.br

List of Technical Assistants on the site:

www.metvisa.com.br

IMG BRASIL PRODUCT MANUFACTURER



IMG BRASIL Gastronomy Machinery Industry Ltda.

CNPJ 11.193.347/0001-14 - CREA 131726-3
Road. Antônio Heil - KM 23 Nº 5825 - Neighborhood: Limoeiro
ZIP CODE 88352-502 - Brusque - SC - Brazil
Phone/fax. +55 47 3251-5555 - Web Site: www.metvisa.com.br
Mail: sac@metvisa.com.br - export@metvisa.com.br



Know our complete
line of products.